



# Lee Surveying and Mapping Co., Inc.



Land Surveys • Topography • Subdivisions • Construction Layout

117 N. Madriver Street  
Bellefontaine OH 43311

Phone: (937) 593-7335  
Fax: (937) 593-7444

## AMOS WAGLER 58.158 ACRES

Lying in Section 10, Town 2, Range 14, Washington Township, Logan County, Ohio.

Being out of the Amos Wagler original 86.504 acre tract as deeded and described in Official Record 341, Page 502, Tract I of the Logan County Records of Deeds and being more particularly described as follows:

Beginning at a 5/8 inch iron rod found on the north line of Section 10 at the intersection with the center-line of County Highway 24.

THENCE, with the center-line of County Highway 24 (50 feet wide), S 4°-56'-33" W, a distance of 119.90 feet to a 1-1/2 inch square iron bar found at an angle point in the center-line of the highway.

THENCE, continuing with the center-line of County Highway 24, S 8°-18'-26" W, a distance of 188.64 feet to a railroad spike set at the TRUE POINT OF BEGINNING.

THENCE, with the lines of the David Merritt 3.018 acre tract (O.R. 154, Pg. 109), the following two (2) courses:

N 89°-33'-26" E, a distance of 451.54 feet to a 5/8 inch iron rod set, passing a 5/8 inch iron rod set at 25.29 feet.

N 0°-19'-37" W, a distance of 305.89 feet to a 5/8 inch iron rod set on the north line of Section 10, and the south line of the Matthew J. Jones 12.273 acre tract (O.R. 127, Pg. 460).

THENCE, with the north line of Section 10 and the south lines of the said 12.273 acre tract, the Richard E. Houchins 11.00 acre tract (O.R. 246, Pg. 448), and the Jeffrey I. Hurley 56.465 acre tract (O.R. 251, Pg. 823), N 89°-31'-52" E, a distance of 1400.46 feet to a 5/8 inch iron rod found.

THENCE, with the west lines of the Phillip J. Kerns original 60.613 acre tract (O.R. 195, Pg. 774), the Rex D. Huffer 12.137 acre tract (O.R. 250, Pg. 331), and the Caroline N. Linet 111.715 acre tract (O.R. 384, Pg. 285), S 0°-48'-18" E, a distance of 1768.56 feet to a 5/8 inch iron rod set.

THENCE, S 89°-24'-48" W, a distance of 533.00 feet to a 5/8 inch iron rod set.

THENCE, N 27°-34'-57" W, a distance of 403.31 feet to a 5/8 inch iron rod set.

THENCE, N 0°-28'-08" W, a distance of 116.50 feet to a 5/8 inch iron rod set.

THENCE, N 87°-34'-31" W, a distance of 1265.46 feet to a railroad spike set, passing a 5/8 inch iron rod set at 1240.33 feet.

THENCE, with the center-line of County Highway 24, N 8°-18'-26" E, a distance of 103.37 feet to a railroad spike found.

THENCE, with the south line of the Julie E. Defibaugh 1.500 acre tract (O.R. 214, Pg. 670), S 81°-41'-14" E, a distance of 290.25 feet to a 5/8 inch iron rod found, passing a 5/8 inch iron rod found at 25.00 feet.

THENCE, with the east line and the east line extended of the said 1.500 acre tract, N 8°-21'-39" E, a distance of 224.95 feet to a 5/8 inch iron rod set.

THENCE, N 81°-41'-32" W, a distance of 290.48 feet to a railroad spike set on the center-line of County Highway 24, passing a 5/8 inch iron rod set at 265.48 feet.

THENCE, with the center-line of County Highway 24, N 8°-18'-26" E, a distance of 585.96 feet to the point of beginning.

Containing 58.158 acres, of which 0.401 acre is within the right-of-way of County Highway 24.

The basis for bearings is the north line of Section 10, being N 89°-31'-52" E, and all other bearings are from angles and distances measured in field surveys by Lee Surveying and Mapping Co., Inc. on October 7, 1997 and October 27, 1998.

Description prepared by:

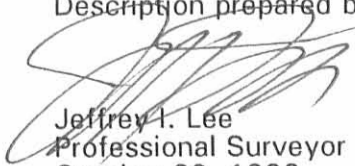
  
Jeffrey I. Lee  
Professional Surveyor 6359  
October 30, 1998

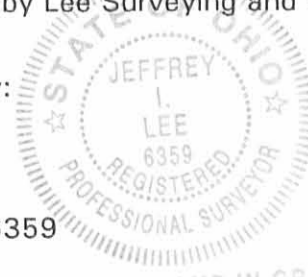

ORIGINAL STAMP IN GREEN L-1758

7961 807

REC'D 11-5-98 SMY OK ✓



# Lee Surveying and Mapping Co., Inc.



Land Surveys • Topography • Subdivisions • Construction Layout

117 N. Madriver Street  
Bellefontaine OH 43311

Phone: (937) 593-7335  
Fax: (937) 593-7444

## AMOS WAGLER 28.750 ACRES

Lying in Section 10, Town 2, Range 14, Washington Township, Logan County, Ohio.

Being out of the Amos Wagler original 86.504 acre tract as deeded and described in Official Record 341, Page 502, Tracts I and II of the Logan County Records of Deeds and being more particularly described as follows:

Beginning at a 5/8 inch iron rod found on the north line of Section 10 at the intersection with the center-line of County Highway 24.

THENCE, with the center-line of County Highway 24 (50 feet wide), S 4°-56'-33" W, a distance of 119.90 feet to a 1-1/2 inch square iron bar found at an angle point in the center-line of the highway.

THENCE, continuing with the center-line of County Highway 24, S 8°-18'-26" W, a distance of 1122.90 feet to a railroad spike set at the TRUE POINT OF BEGINNING.

THENCE, S 87°-34'-31" E, a distance of 1265.46 feet to a 5/8 inch iron rod set, passing a 5/8 inch iron rod set at 25.13 feet.

THENCE, S 0°-28'-08" E, a distance of 116.50 feet to a 5/8 inch iron rod set.

THENCE, S 27°-34'-57" E, a distance of 403.31 feet to a 5/8 inch iron rod set.

THENCE, N 89°-24'-48" E, a distance of 533.00 feet to a 5/8 inch iron rod set.

THENCE, with a west line of the Carolyn N. Linet 111.715 acre tract, (O.R. 384, Pg. 285), S 0°-48'-18" E, a distance of 457.00 feet to an 18 inch concrete post found.

THENCE, with a north line of the said 111.715 acre tract, and the north line of the Stephen Robert Jacks 71.42 acre tract, (O.R. 75, Pg. 31), S 89°-24'-48" W, a distance of 1798.50 feet to a 1/2 inch iron rod found.

THENCE, with the lines of the David F. Downing 8.425 acre tract, (O.R. 109, Pg. 205), the following six (6) courses:

N 2°-46'-29" W, a distance of 309.33 feet to a 3/4 inch iron rod found.

S 89°-56'-38" E, a distance of 490.12 feet to a 5/8 inch iron rod found.

N 7°-16'-12" W, a distance of 362.99 feet to a 5/8 inch iron rod found.

S 88°-04'-46" W, a distance of 302.33 feet to a 5/8 inch iron rod found.

N 0°-17'-03" E, a distance of 162.33 feet to an 18 inch concrete post found.

S 89°-22'-34" W, a distance of 96.18 feet to a 1/2 inch iron rod found.

THENCE, with the northerly line of the David F. Downing 1.553 acre tract (O.R. 109, Pg. 205), N 83°-37'-16" W, a distance of 273.18 feet to a railroad spike found on the center-line of County Highway 24, passing a 5/8 inch iron rod found at 248.17 feet.

THENCE, with the center-line of County Highway 24, N 8°-18'-26" E, a distance of 150.00 feet to the point of beginning.

Containing 28.750 acres, of which 0.087 acre is within the right-of-way of County Highway 24.

The basis for bearings is the north line of Section 10, being N 89°-31'-52" E, and all other bearings are from angles and distances measured in field surveys by Lee Surveying and Mapping Co., Inc. on October 7, 1997 and October 27, 1998.

Description prepared by:

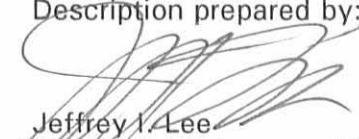
  
Jeffrey I. Lee  
Professional Surveyor 6359  
October 30, 1998

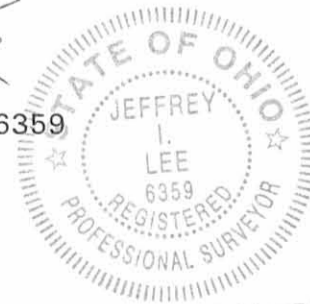

L-1758

INCLUDE TO MAP  
79618D-2

ORIGINAL STAMP IN GREEN

REC'D 11-10-98 SMM ok ✓

2 WORKING DAYS  
**BEFORE YOU DIG**  
CALL TOLL FREE **800-362-2764**  
OHIO UTILITIES PROTECTION SERVICE.

MATTHEW J. JONES  
12.273 ACRES  
O.R. 127, PG. 460

RICHARD E. HOCHINS  
11.00 ACRES  
O.R. 246, PG. 448

JEFFREY I. HURLEY  
56.465 ACRES  
O.R. 251, PG. 823

SECTION 11  
SECTION 10

SECTION 11  
SECTION 10

(BASIS FOR BEARINGS) N 89°31'52"E  
1400.46'

S 04°56'33"W  
119.90'  
STA 216+40  
25.29'  
S 08°18'26"W  
188.64'  
N 89°33'26"E  
451.54'  
N 00°19'37"W  
305.89'

DAVID MERRITT  
3.018 ACRES  
O.R. 154, PG. 109

58.158 ACRES  
OF WHICH 0.401 ACRE IS WITHIN  
THE HIGHWAY RIGHT-OF-WAY

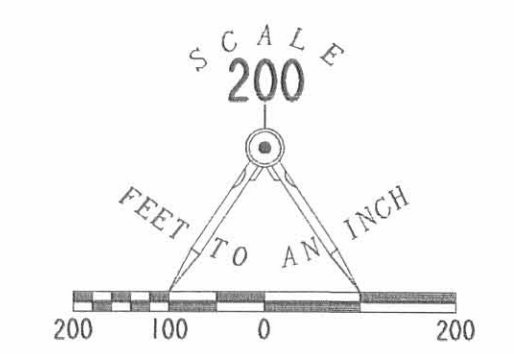
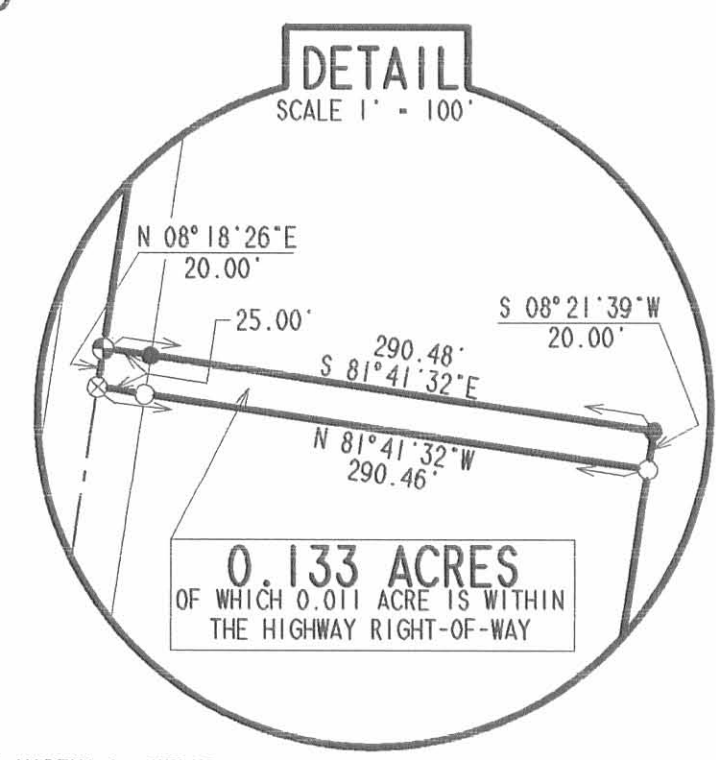

0.133 ACRES  
OF WHICH 0.011 ACRE IS WITHIN  
THE HIGHWAY RIGHT-OF-WAY

LEGEND

- ⊙ RAILROAD SPIKE SET
- ⊗ RAILROAD SPIKE FOUND
- 5/8" IRON ROD SET
- 5/8" IRON ROD FOUND
- ⦿ 3/4" IRON ROD FOUND
- ⊕ 1/2" IRON ROD FOUND
- ⊗ 18" CONCRETE POST FOUND
- ⊠ 1.5" SQUARE IRON BAR FOUND

REFERENCES

LOGAN COUNTY MAP ROOM FILES:  
FB.601, PPS. 20 THRU 23  
R-7961, R-8483, R-3685

SEE DETAIL

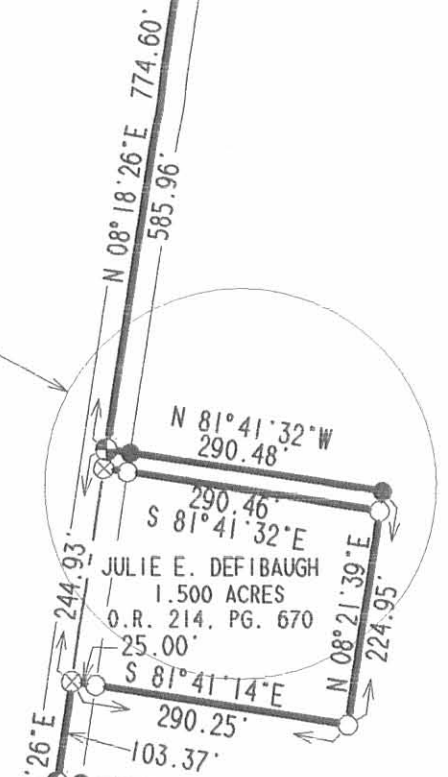

JULIE E. DEFIBAUGH  
1.500 ACRES  
O.R. 214, PG. 670

AMOS WAGLER  
ORIG. 93.00 ACRE TRACT  
O.R. 341, PG. 502, TRACT I

PHILLIP E. KERNS & MARTHA L. KERNS  
60.613 ACRES  
O.R. 195, PG. 774

REX D. HUFFER  
12.137 ACRES  
O.R. 250, PG. 331

N 08°18'26"E 774.60'  
585.96'  
N 87°34'31"W 1265.46'  
S 89°22'34"W 96.18'  
N 83°37'16"W 273.18'  
N 00°17'03"E 162.33'  
S 88°04'46"W 302.33'  
N 07°16'12"W 362.99'  
S 89°56'38"E 490.12'  
N 02°46'29"W 309.33'  
1798.50'  
S 89°24'48"W

DAVID F. DOWNING  
8.425 ACRES  
O.R. 109, PG. 205

28.750 ACRES  
OF WHICH 0.087 ACRE IS WITHIN  
THE HIGHWAY RIGHT-OF-WAY

TRACT 11  
ORIG. 8.0 ACRE

STEPHEN ROBERT JACKS  
71.42 ACRES  
O.R. 75., PG. 31

CAROLYN N. LINET  
ORIG. 111.715 ACRES  
O.R. 384, PG. 285

SURVEY OF THREE TRACTS OUT OF  
THE AMOS WAGLER  
ORIGINAL 86.504 (DEED) ACRE TRACT  
OFFICIAL RECORD 341, PAGE 502, TRACT I & II  
SECTION 10, TOWN 2, RANGE 14  
WASHINGTON TOWNSHIP  
LOGAN COUNTY, OHIO

SURVEYED BY:

JEFFREY I. LEE  
PROFESSIONAL SURVEYOR 6359  
OCTOBER 8, 1997  
REVISED DATE: OCTOBER 27, 1998



COPYRIGHT 1997 BY:  
LEE SURVEYING & MAPPING CO., INC.  
117 North Madriver Street  
BELLEFONTAINE, OHIO 43311  
(937) 593-7335

ORIGINAL STAMP IN GREEN

D 320 AMOWAG2 L-1758-2

COUNTY HIGHWAY 24 (50')  
N 09°56'07"E 815.65'

WASHINGTON TOWNSHIP  
PLEASANT TOWNSHIP

INDEXED ON MAP  
7961 SP

Received 2-2-01 OK ght

# Lee Surveying and Mapping Co., Inc.

Land Surveys • Topography • Subdivisions • Construction Layout

117 N. Madriver St.  
Bellefontaine OH 43311



Phone: (937) 593-7335  
Fax: (937) 593-7444

## WAGLER 25.846 ACRES

Lying in Section 10, Town 2, Range 14, Washington Township, Logan County, Ohio.

Being out of the Amos Wagler original 93.000 acre tract as deeded and described in Official Record 341, Page 502, Tract I of the Logan County Records of Deeds and being more particularly described as follows:

Beginning at 5/8 inch iron rod found at the intersection of the north line of Section 10 and the center-line of County Highway 24.

THENCE, with the center-line of County Highway 24 (50 feet wide), S 4°-56'-33" W, a distance of 119.90 feet to a 1.5 inch square iron bar found at Station 216 + 40 as shown in the Logan County Engineer's Field Book 601, Page 20.

THENCE, continuing with the center-line of County Highway 24, S 8°-18'-26" W, a distance of 188.64 feet to a railroad spike set at the TRUE POINT OF BEGINNING.

THENCE, with the south line of the David Merrit 3.018 acre tract (O.R. 154, Pg. 109), N 89°-33'-26" E, a distance of 451.54 feet to a 5/8 inch iron rod set, passing a 5/8 inch iron rod set at 25.29 feet.

THENCE, with the east line of the said 3.018 acre tract, N 00°-19'-37" W, a distance of 305.89 feet to a 5/8 inch iron rod set.

THENCE, with the south line of Section 11 and the south lines of the Matthew J. Jones 12.273 acre tract (O.R. 127, Pg. 460), the Richard E. Houchins 11.00 acre tract (O.R. 246, Pg. 448) and the Jeffrey I. Hurley 56.465 acre tract (O.R. 251, Pg. 823), N 89°-31'-52" E, a distance of 1400.46 feet to a 5/8 inch iron rod found.

THENCE, with the west line of the Phillip E. Kerns 60.613 acre tract (O.R. 195, Pg. 774), S 00°-48'-18" E, a distance of 809.98 feet to a 5/8 inch iron rod set.

THENCE, N 89°-57'-14" W, a distance of 676.17 feet to a 5/8 inch iron rod set.

THENCE, N 00°-11'-49" E, a distance of 194.24 feet to a 5/8 inch iron rod set.

THENCE, N 89°-57'-14" W, a distance of 1228.92 feet to a MAG nail set, passing a 5/8 inch iron rod set at 1203.63 feet.

THENCE, with the center-line of County Highway 24, N 8°-18'-44" E, a distance of 296.40 feet to the place of beginning.

Containing 25.846 acres of which 0.170 acre is within the highway right-of-way.

The basis for bearings is the south line of Section 11 being N 89°-31'-52" E, and all other bearings are from angles and distances measured in a field survey by Lee Surveying and Mapping Co., Inc. on September 21, 2000.

Description prepared by:

William K. Bruce  
Professional Surveyor 7437  
September 25, 2000

INDEXED ON MAP  
7961 9D-1



ORIGINAL STAMP IN GREEN 1758

Received 2-2-01-OK gms  
**Lee Surveying and Mapping Co., Inc.**

Land Surveys • Topography • Subdivisions • Construction Layout

117 N. Madriver St.  
Bellefontaine OH 43311



Phone: (937) 593-7335  
Fax: (937) 593-7444

**WAGLER  
15.812 ACRES**

Lying in Section 10, Town 2, Range 14, Washington Township, Logan County, Ohio.

Being out of the Amos Wagler original 93.000 acre tract as deeded and described in Official Record 341, Page 502, Tract I of the Logan County Records of Deeds and being more particularly described as follows:

Beginning at 5/8 inch iron rod found at the intersection of the north line of Section 10 and the center-line of County Highway 24.

THENCE, with the center-line of County Highway 24 (50 feet wide), S 4°-56'-33" W, a distance of 119.90 feet to a 1.5 inch square iron bar found at Station 216 + 40 as shown in the Logan County Engineer's Field Book 601, Page 20.

THENCE, continuing with the center-line of County Highway 24, S 8°-18'-26" W, a distance of 188.64 feet to a railroad spike set.

THENCE, continuing with the center-line of County Highway 24, S 8°-18'-44" W, a distance of 296.40 feet to a MAG nail set at the TRUE POINT OF BEGINNING.

THENCE, S 89°-57'-14" E, a distance of 1228.92 feet to a 5/8 inch iron rod set, passing a 5/8 inch iron rod set at 25.29 feet.

THENCE, S 00°-11'-49" W, a distance of 194.24 feet to a 5/8 inch iron rod set.

THENCE, S 89°-57'-14" E, a distance of 676.17 feet to a 5/8 inch iron rod set.

THENCE, with the west lines of the Phillip E. Kerns 60.613 acre tract (O.R. 195, Pg. 774), and the Rex D. Huffer 12.137 acre tract (O.R. 250, Pg. 331), S 00°-48'-18" E, a distance of 400.00 feet to a 5/8 inch iron rod set.

THENCE, S 89°-59'-38" W, a distance of 687.36 feet to a 5/8 inch iron rod set.

THENCE, N 00°-00'-00" W, a distance of 207.69 feet to a 5/8 inch iron rod set.

THENCE, N 84°-57'-20" W, a distance of 1268.01 feet to a MAG nail set, passing a 5/8 inch iron rod set at 1242.97 feet.

THENCE, with the center-line of County Highway 24, N 8°-18'-44" E, a distance of 279.56 feet to the place of beginning.

Containing 15.812 acres of which 0.161 acre is within the highway right-of-way.

The basis for bearings is the south line of Section 11 being N 89°-31'-52" E, and all other bearings are from angles and distances measured in a field survey by Lee Surveying and Mapping Co., Inc. on September 21, 2000.

Description prepared by:

A handwritten signature in black ink, appearing to read 'William K. Bruce', is written over the typed name.

William K. Bruce  
Professional Surveyor 7437  
October 30, 2000



Lee Surveying and Mapping Co., Inc.

Land Surveys • Topography • Subdivisions • Construction Layout

117 N. Madriver St.  
Bellefontaine OH 43311



Phone: (937) 593-7335  
Fax: (937) 593-7444

WAGLER  
16.633 ACRES

Lying in Section 10, Town 2, Range 14, Washington Township, Logan County, Ohio.

Being out of the Amos Wagler original 93.000 acre tract as deeded and described in Official Record 341, Page 502, Tract I of the Logan County Records of Deeds and being more particularly described as follows:

Beginning at 5/8 inch iron rod found at the intersection of the north line of Section 10 and the center-line of County Highway 24.

THENCE, with the center-line of County Highway 24 (50 feet wide), S 4°-56'-33" W, a distance of 119.90 feet to a 1.5 inch square iron bar found at Station 216+40 as shown in the Logan County Engineer's Field Book 601, Page 20.

THENCE, continuing with the center-line of County Highway 24, S 8°-18'-26" W, a distance of 188.64 feet to a railroad spike set.

THENCE, continuing with the center-line of County Highway 24, S 8°-18'-44" W, a distance of 575.96 feet to a MAG nail set at the TRUE POINT OF BEGINNING.

THENCE, S 84°-57'-20" E, a distance of 1268.01 feet to a 5/8 inch iron rod set, passing a 5/8 inch iron rod set at 25.04 feet.

THENCE, S 00°-00'-00" E, a distance of 207.69 feet to a 5/8 inch iron rod set.

THENCE, N 89°-59'-38" E, a distance of 687.36 feet to a 5/8 inch iron rod set.

THENCE, with the west line the Rex D. Huffer 12.137 acre tract (O.R. 250, Pg. 331) and the Carolyn N. Linet 111.715 acre tract (O.R. 384, Pg. 285, Tract II), S 00°-48'-18" E, a distance of 558.58 feet to a 5/8 inch iron rod set.

THENCE, with the lines of the Amos A. Schwartz 28.750 acre tract (O.R. 403, Pg. 833), the following four courses:

S 89°-24'-48" W, a distance of 533.00 feet to a 5/8 inch iron rod set.

N 27°-34'-57" W, a distance of 403.31 feet to a 5/8 inch iron rod set.

N 00°-28'-08" W, a distance of 116.50 feet to a 5/8 inch iron rod set.

N 87°-34'-31" W, a distance of 1290.59 feet to a railroad spike set, passing a 5/8 inch iron rod set at 1265.46 feet.

THENCE, with the center-line of County Highway 24, N 8°-18'-26" E, a distance of 103.37 feet to a railroad spike found.

THENCE, with the lines of the Stan L. Hudson Jr. 1.500 acre tract (O.R. 400, Pg. 349), the following three courses:

S 81°-41'-14" E, a distance of 290.31 feet to a 5/8 inch iron rod found, passing a 5/8 inch iron rod found at 30.08 feet.

N 8°-21'-39" E, a distance of 224.95 feet to a 5/8 inch iron rod found.

N 81°-41'-32" W, a distance of 290.52 feet to a railroad spike found, passing a 5/8 inch iron rod set at 260.60 feet.

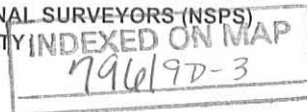

# Lee Surveying and Mapping Co., Inc.

Land Surveys • Topography • Subdivisions • Construction Layout

117 N. Madriver St.  
Bellefontaine OH 43311



Phone: (937) 593-7335  
Fax: (937) 593-7444

THENCE, with the center-line of County Highway 24, N 8°-18'-44" E, a distance of 30.00 feet to the place of beginning.

Containing 16.633 acres of which 0.084 acre is within the highway right-of-way.

The basis for bearings is the south line of Section 11 being N 89°-31'-52" E, and all other bearings are from angles and distances measured in a field survey by Lee Surveying and Mapping Co., Inc. on September 21, 2000.

Description prepared by:

A handwritten signature in black ink that reads 'William K. Bruce'.

William K. Bruce  
Professional Surveyor 7437  
September 25, 2000  
Revised: January 29, 2001



ORIGINAL STAMP IN GREEN

L-1758

INDEXED ON MAP  
7961 90-4

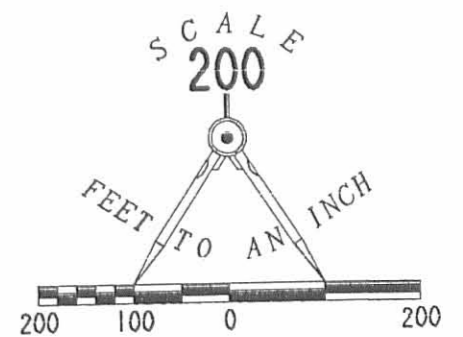
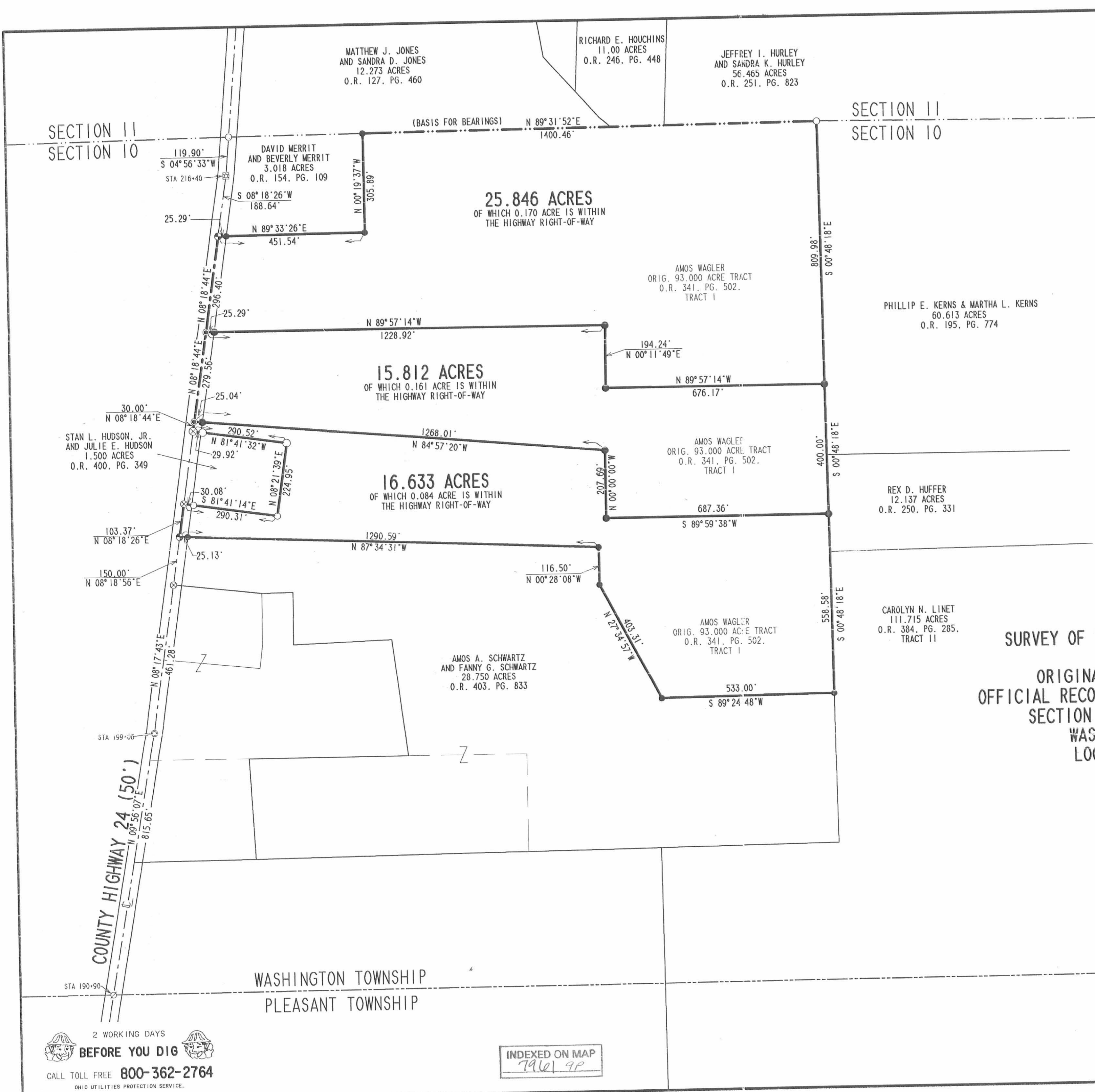

- LEGEND**
- 5/8" IRON ROD SET
  - ⊕ RAILROAD SPIKE SET
  - ⊙ MAG NAIL SET
  - 5/8" IRON ROD FOUND
  - ⊗ RAILROAD SPIKE FOUND
  - ⊠ 1.5" SQUARE IRON BAR FOUND
  - 1/2 INCH IRON ROD FOUND
  - ⊙ 3/4 INCH IRON ROD FOUND

**REFERENCES**  
 LOGAN COUNTY MAP ROOM FILES:  
 FB. 601, PPS. 20 THRU 23  
 R-7961, R-8483, R-3685

**SURVEY OF THREE TRACTS OUT OF THE  
 AMOS WAGLER  
 ORIGINAL 93,000 ACRE TRACT  
 OFFICIAL RECORD 341, PAGE 502, TRACT I  
 SECTION 10, TOWN 2, RANGE 14  
 WASHINGTON TOWNSHIP  
 LOGAN COUNTY, OHIO**

SURVEYED BY:  
  
 JEFFREY I. LEE  
 PROFESSIONAL SURVEYOR 6359  
 OCTOBER 23, 2000



COPYRIGHT 1997 BY:  
**LEE SURVEYING & MAPPING CO., INC.**  
 117 North Madriver Street  
 BELLEFONTAINE, OHIO 43311  
 (937) 593-7335  
 D-386 AMOWAG3A.GCD L-1758-2  
 AMOWAG.DAT

ORIGINAL STAMP IN GREEN

2 WORKING DAYS  
**BEFORE YOU DIG**  
 CALL TOLL FREE 800-362-2764  
 OHIO UTILITIES PROTECTION SERVICE.

INDEXED ON MAP  
 79601 9P





**DESCRIPTION OF SURVEY FOR  
ADEN S. MILLER AND AMOS G. WAGLER  
3.300 ACRES  
JULY 19, 2022**

The following described 3.300 acre tract of land is situated in the northwest quarter of Section 10, Town 2, Range 14, B.M.R.S., Washington Township, Logan County, Ohio and being part of Amos G. Wagler's and Esther Wagler's Tract I (15.812 acres) described in Official Record Volume 1127, page 746, said 3.300 acre tract more particularly described as follows:

Beginning for reference at a 5/8 inch iron bar found at the intersection of the centerline of County Road 24 (50 feet wide) with the north line of Section 10;

Thence South 10°49'44" West 119.80 feet, following the centerline of County Road 24 and entering the northwest quarter of Section 10, to a 1-1/2 inch square iron bar found;

Thence South 14°11'02" West 485.04 feet, continuing along the centerline of County Road 24, to a magnetic nail found at the southwest corner of Aden S. Miller's and Amanda G. Miller's 25.846 acre tract described in Official Record Volume 483, page 319 and at the northwest corner of said 15.812 acre tract;

Thence South 84°05'22" East 1229.06 feet, departing from the centerline of County Road 24, following a north line of said 15.812 acre tract and a south line of said 25.846 acre tract, to a 5/8 inch iron bar found;

Thence South 6°05'46" West 194.39 feet, following an east line of said 15.812 acre tract and a west line of said 25.846 acre tract, to a 5/8 inch iron bar found and marking the **place of beginning**;

Thence **South 84°04'41" East 676.42 feet**, following a north line of said 15.812 acre tract and a south line of said 25.846 acre tract, to a 5/8 inch iron bar found in the east line of the northwest quarter of Section 10 and in the west line of Shawn J. Bihn's and Amy S. Bihn's Parcel I (33.196 acres) described in Official Record Volume 1118, page 615;

Thence **South 05°08'52" West 211.18 feet**, following the east line of the northwest quarter of Section 10, the east line of said 15.812 acre tract and the west line of said 33.196 acre tract, to an iron bar set;



Thence **North 84°04'41" West 685.03 feet**, departing from the west line of said 33.196 acre tract, re-entering the northwest quarter of Section 10 and crossing said 15.812 acre tract, to an iron bar set in an east line of Amos G. Wagler's and Esther Wagler's Tract II (16.633 acres) described in Official Record Volume 1127, page 746;

Thence **North 7°28'57" East 211.24 feet**, following a west line of said 15.812 acre tract and an east line of said 16.633 acre tract, passing at 18.19 feet a 5/8 inch iron bar found at a southeast corner of said 15.812 acre tract, crossing said 15.812 acre tract thereafter, to the **place of beginning, containing 3.300 acres** more or less and subject to all valid easements and restrictions of record.

The 3.300 acre tract described herein is to be attached to an adjoining parcel and may not be used as a separate or independent tract.

This description was prepared in the absence of a complete and accurate title search and does not guarantee title.

The above description was prepared from an actual field survey made by Blackburn Surveying LLC, George A. Blackburn, Registered Surveyor #7873, during the month of July 2022. Iron bars set are 5/8 inch by 30 inch reinforcing rods with plastic caps marked "Blackburn RS #7873." Bearings indicated herein are based on the centerline of County Road 24 bearing South 14°11'02" West.

Description prepared by: *George A. Blackburn* 7-19-2022

George A. Blackburn, R.S. #7873  
6879 State Route 287  
West Liberty, Ohio 43357  
(937) 465-0424



INDEXED ON MAP  
7961

PLAT OF SURVEY IN THE  
 N.W. QUARTER OF SECTION 10, TOWN 2, RANGE 14  
 BETWEEN THE MIAMI RIVER SURVEY  
 WASHINGTON TOWNSHIP  
 LOGAN COUNTY, OHIO

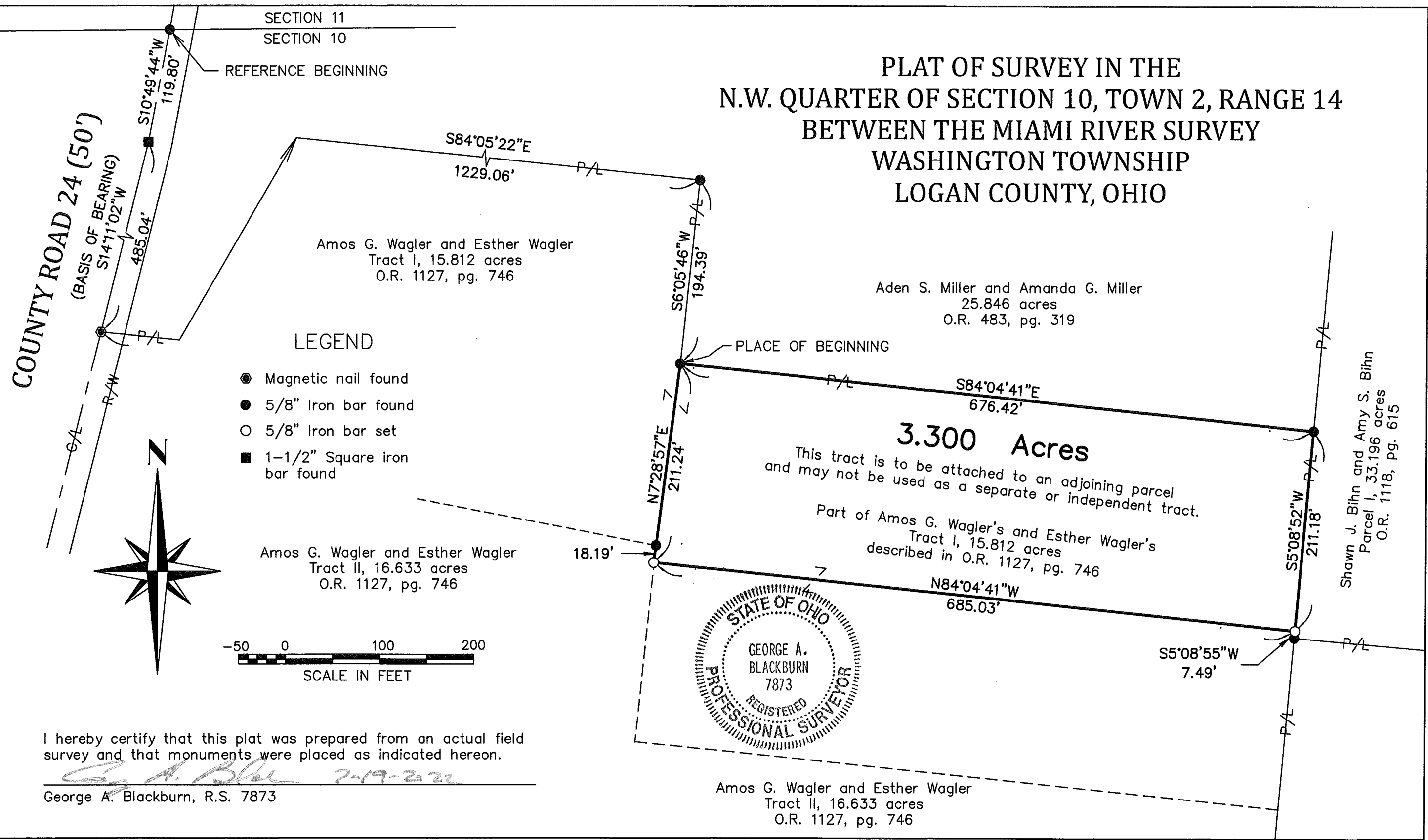

- LEGEND**
- Magnetic nail found
  - 5/8" Iron bar found
  - 5/8" Iron bar set
  - 1-1/2" Square iron bar found



I hereby certify that this plat was prepared from an actual field survey and that monuments were placed as indicated hereon.  
*George A. Blackburn* 7-19-2022  
 George A. Blackburn, R.S. 7873

BLACKBURN SURVEYING, LLC  
 6879 STATE ROUTE 287  
 WEST LIBERTY, OHIO 43357  
 (937) 465-0424

DATE: 7/19/2022  
 SCALE: 1" = 100'  
 FILE: Aden Miller 7-22

REVISIONS	DATE	BY

PLAT PREPARED FOR ADEN S. MILLER AND AMOS G. WAGLER

SHEET  
 1  
 OF 1

INDEXED ON MAP  
 7961



**APPROVED**



**Description  
3.000 Acres**

- Situated in Section 10 Town 2, Range 14, Washington Township, Logan County, Ohio, being part of a 16.633 acre tract hereto conveyed to John M. and Fannie G. Wagler, as recorded in Official Record Volume 1410, Page 3645 Tract II, of said County Deed Records and being more particularly described as follows;
- Commencing at the intersection of the north line of Section 10 with the centerline of County Road 24 (50' R/W), being a 5/8" iron pin found;
- Thence along the centerline of County Road 24, S.10°48'38"W., a distance of 119.90 feet to a 1-1/2" square iron bar found;
- Thence continuing along the centerline of County Road 24, S.14°10'45"W., a distance of 794.60 feet to a railroad spike found;
- Thence continuing along the centerline of County Road 24, S.14°10'31"W., a distance of 224.92 feet to a railroad spike found at the southwest corner of a 1.50 acre tract conveyed to Theodore D. Daniels, Et. Al. as recorded in Official Record Volume 795, Page 64, being the **Principal Point of Beginning**;
- Thence running along said 1.50 acre tract on the following two (2) courses and distances:
  1. S.75°49'09"E., a distance of 290.31 feet to 5/8" iron pin found, passing a 5/8" iron pin found at 30.08 feet;
  2. N.14°13'44"E., a distance of 141.19 feet to 5/8" iron pin set;
- Thence running along a new division line on the following two (2) courses and distances:
  1. S.81°42'26"E., a distance of 421.31 feet to 5/8" iron pin set;
  2. S.20°51'33"E., a distance of 244.44 feet to 5/8" iron pin set in the south line of said 16.633 acre tract and the north line of a 28.750 acre tract conveyed to Jacob R. and Rosa Schwartz in Official Record Volume 1406, Page 4877, Tract III;
- Thence along the south line and north line of said tracts, N.81°42'26"W., a distance of 854.39 feet to a railroad spike found in the centerline of County Road 24, passing a 5/8" iron pin found at 829.26 feet;
- Thence on said centerline County Road 24, N.14°11'01"E., a distance of 103.37 feet to the **Point of Beginning**;
- Containing 3.000 acres, more or less of which 0.021 acre lie in Road Right of Way and being subject to all legal highways, rights-of-way, easements, restrictions, covenants, and/or conditions of record.

The above description based on a survey prepared by Michael L. Howbert, Registered Professional Surveyor No. 7959, in October of 2024. The basis of bearing is based on Ohio North State Plane Grid, NAD 83, Adjustment 2011.

  
Michael L. Howbert, P.S.



INDEXED ON MAP  
7961



### Description 7.000 Acres

- Situated in Section 10 Town 2, Range 14, Washington Township, Logan County, Ohio, being part of a 16.633 acre tract hereto conveyed to John M. and Fannie G. Wagler, as recorded in Official Record Volume 1410, Page 3645, of said County Deed Records and being more particularly described as follows;
- Commencing at the intersection of the north line of Section 10 with the centerline of County Road 24, being a 5/8" iron pin found;
- Thence along the centerline of County Road 24, S.10°48'38"W., a distance of 119.90 feet to a 1-1/2" square iron bar found;
- Thence continuing along the centerline of County Road 24, S.14°10'45"W., a distance of 794.60 feet to a railroad spike found;
- Thence continuing along the centerline of County Road 24, S.14°10'31"W., a distance of 224.92 feet to a railroad spike found;
- Thence continuing along the centerline of County Road 24, S.14°11'01"W., a distance of 103.37 feet to a railroad spike found at the southwest corner of said 16.633 acre tract and at the northwest corner of a 28.750 acre tract conveyed to Jacob R. and Rosa Schwartz as recorded in Official Record Volume 1406, Page 4877 Tract III;
- Thence along the south line and north line of said tracts, S.81°42'26"E., a distance of 1290.59 feet to a 5/8" iron pin found, being the *Principal Point of Beginning*;
- Thence on a new division line, S.84°08'53"E., a distance of 714.08 feet to a 5/8" iron pin set in the east line of said 16.633 acre tract;
- Thence along the east line of said tract and the west line of a 12.122 acre tract conveyed to Justin R. Harpst and Heather N. Allen as recorded in Official Record Volume 1248, Page 21, Parcel One and the west line of a 111.715 acre tract conveyed to Jack E. Linet as recorded in Official Record Volume 1262, Page 688, S.05°03'47"W., a distance of 468.76 feet to a 5/8" iron pin found at the northeast corner of said 28.750 acre tract;
- Thence running along said 16.633 acre tract and the north line of said 28.750 acre on the following three (3) courses and distances:
  1. N.84°43'07"W., a distance of 533.00 feet to 5/8" iron pin found;
  2. N.21°42'52"W., a distance of 403.31 feet to 5/8" iron pin found;
  3. N.05°23'57"E., a distance of 116.50 feet to the **Point of Beginning**;
- Containing 7.000 acres, more or less and being subject to all legal highways, rights-of-way, easements, restrictions, covenants, and/or conditions of record.

The above description based on a survey prepared by Michael L. Howbert, Registered Professional Surveyor No. 7959, in October of 2024. The basis of bearing is based on Ohio North State Plane Grid, NAD 83, Adjustment 2011.

  
Michael L. Howbert, P.S.

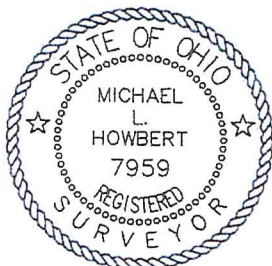

10-29-2024

 **APPROVED**

# PLAT OF SURVEY FOR JOHN WAGLER

SITUATED IN:  
SECTION 10  
TOWN 2, RANGE 14,  
WASHINGTON TOWNSHIP,  
LOGAN COUNTY, OHIO

NORTH AND BEARING  
SYSTEM BASED ON  
OHIO NORTH STATE  
PLANE GRID, NAD 83  
ADJ. 2011.

**COUNTY ROAD 24 (50')**



N14°11'01"E  
S14°10'31"W  
S14°10'45"W  
S10°48'38"W  
119.90'  
794.60'  
224.92'  
103.37'  
30.08'  
25.13'

THEODORE D. DANIELS, ET. AL.  
O.R. 795, PG. 64  
1.50 AC.  
POB  
3.000 AC.

**3.000 ACRES**

JOHN M. AND FANNIE B. WAGLER,  
TRACT II  
O.R. 1410, PG. 3645  
16.633 AC.

JACOB R. AND ROSA SCHWARTZ  
O.R. 1406, PG. 4877, TRACT III  
28.750 AC.

- LEGEND:**
-  1-1/2" SQUARE IRON BAR FOUND
  -  RAILROAD SPIKE FOUND
  -  5/8" IRON PIN FOUND
  -  5/8" IRON PIN W/ CAP SET

POB  
7.000 AC.  
S81°42'26"E 436.20'

S84°08'53"E 714.08'

**7.000 ACRES**

JUSTIN R. HARPST & HEATHER N. ALLEN  
O.R. 1248, PG. 21, PARCEL ONE  
12.122 AC.

JACK EARL LINET  
O.R. 1262, PG. 688  
111.715 AC.



**HOWBERT  
SURVEYING  
LLC**  
8477 MERICLE ROAD  
FORT JENNINGS, OHIO 45844  
419-863-0289

THIS PLAT IS BASED ON AN ACTUAL FIELD SURVEY.

  
**MICHAEL L. HOWBERT**  
REGISTERED PROFESSIONAL  
SURVEYOR NO. 7959 IN OHIO  
OCTOBER 24, 2024

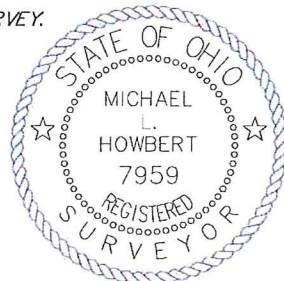

**NOTES:**  
FOUND MONUMENTATION IN GOOD CONDITION  
UNLESS OTHERWISE NOTED.  
DATA SOURCES INCLUDE DOCUMENTS CITED.  
A TITLE SEARCH IS RECOMMENDED TO DETERMINE  
EASEMENTS, RESTRICTIONS, AND/OR OTHER  
ENCUMBRANCES AFFECTING THE PROPERTY  
SHOWN HEREON.

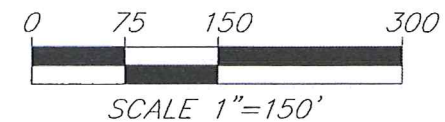

**INDEXED ON MAP**  
7961

DATE: 10/24/24	REV.:
CLIENT: J WAGLER	SCALE: 1" = 150'
JOB #: 785-10-24	CHK:

FILE: JWA GLR24.DWG