

REC'D 9-9-03 SMALL

SURVEY FOR STEVE GREGG
5.036 Acres
September 3, 2003

The following described 5.036 acre tract is situated in the State of Ohio, County of Logan, Township of Rushcreek, V.M.S. 3326, being part of Steven R. and Bonnie L. Gregg's 57.55 acre tract described in Official Record 105, page 556, said 5.036 acre tract being more particularly described as follows:

Beginning for reference at a 5/8 inch iron pin with cap marked "LOGAN COUNTY ENGINEER" in a monument box found at the intersection of the centerline of County Road #5 with the northeastern terminus point of Township Road #273 (50 feet wide);

Thence South 71°09'58" West (assumed bearing) 791.13 feet, following the centerline of Township Road #273, to a railroad spike found;

Thence South 76°09'53" West 363.76 feet, departing from the centerline of said Road, to a magnetic nail set South 72°59'27" West 1.43 feet from an iron pin set over a 2 inch iron pipe found 30 inches below the surface of said Road, said nail marking the **place of beginning**;

Thence **South 17°28'12" East 437.12 feet**, following the east line of said 57.55 acre tract and crossing said Road, passing at 4.43 feet the centerline of said Road and at 29.38 feet a 5/8 inch iron pin found with cap marked "LEE PS-6359" at the northwest corner of The Board of Logan County Commissioners' 0.158 acre tract described in Official Record 404, page 593, thereafter also following the west line of said 0.158 acre tract, also passing at 34.38 feet the northwest corner of Carl Burkholder's 3.417 acre tract described in Official Record 404, page 608, thereafter also following the west line of said 3.417 acre tract, to an iron pin set;

Thence **South 76°22'51" West 527.38 feet**, departing from the west line of said 3.417 acre tract and entering said 57.55 acre tract, to an iron pin set;

Thence **North 15°47'05" West 406.01 feet**, passing at 394.37 feet an iron pin set on the southern right of way line of said Road and thereafter entering said Road, to an iron pin set in the north line of said 57.55 acre tract;

Thence **North 72°59'27" East 514.27 feet**, following the north line of said 57.55 acre tract and passing at 411.91 feet the centerline of said Road, to the **place of beginning, containing 5.036 acres**, more or less, and being subject to all valid easements and restrictions of record.

The above description was prepared from a field survey made under the supervision of Paul R. Clapsaddle, Registered Surveyor #6140, during the month of September 2003. Bearings indicated herein are based on an assumed meridian with all others based on angles turned. Iron pins set are 5/8 inch by 30 inch reinforcing rods with caps marked "CLAPSADDLE RS #6140".

ATTEST:

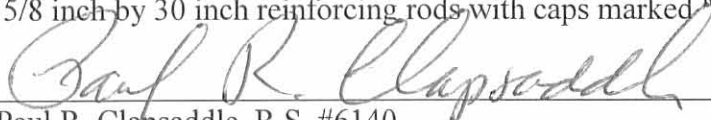
Paul R. Clapsaddle, R.S. #6140

19019 West Darby Road, Marysville, Ohio 43040
(937) 747-2599

INDEXED ON MAP
9452 1D

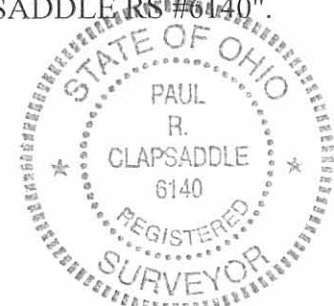

REID99-03 SUMOR

SURVEY FOR STEVEN GREGG

State of Ohio, County of Logan, Township of Rushcreek, V.M.S. 3326, being part of Steven R. and Bonnie L. Gregg's 57.55 acre tract described in Official Record 105, page 556

- LEGEND:**
- Railroad spike found
 - ⊙ 5/8 inch iron pin found with cap marked "LEE PS-6359" unless otherwise noted
 - ⊙ 5/8 inch iron pin set with cap marked "CLAPSADDLE RS #6140" in a 2 inch iron pipe found 30 inches deep
 - ⊙ 5/8 inch iron pin with cap marked "LOGAN COUNTY ENGINEER" in a monument box found
 - Magnetic nail set
 - 5/8 inch iron pin set with cap marked "CLAPSADDLE RS#6140"

NOTES:

Reference deeds are shown hereon.

Bearings indicated hereon are based on an assumed meridian with all others based on angles turned.

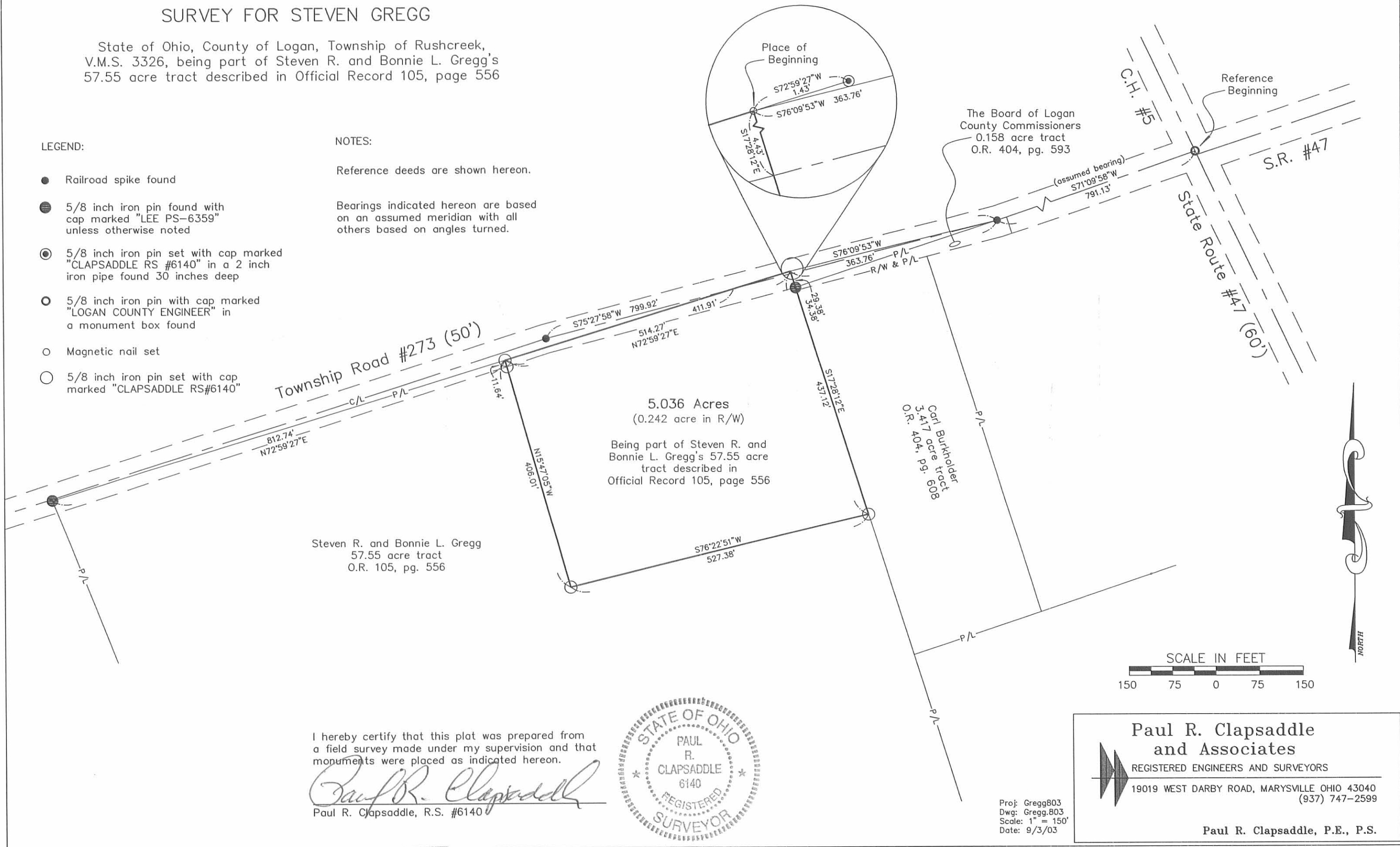

I hereby certify that this plat was prepared from a field survey made under my supervision and that monuments were placed as indicated hereon.

Paul R. Clapsaddle
 Paul R. Clapsaddle, R.S. #6140



Paul R. Clapsaddle and Associates
 REGISTERED ENGINEERS AND SURVEYORS
 19019 WEST DARBY ROAD, MARYSVILLE OHIO 43040
 (937) 747-2599

Proj: Gregg803
 Dwg: Gregg.803
 Scale: 1" = 150'
 Date: 9/3/03

Paul R. Clapsaddle, P.E., P.S.

INDEXED ON MAP
 9452 1P

REC'D 10-3-03

SURVEY FOR STEVEN GREGG
6.163 Acres
September 18, 2003

The following described 6.163 acre tract is situated in the State of Ohio, County of Logan, Township of Rushcreek, V.M.S. 3326, being part of Steven R. and Bonnie L. Gregg's 57.55 acre tract described in Official Record 105, page 556, said 6.163 acre tract being more particularly described as follows:

Beginning for reference at a 5/8 inch iron pin with cap marked "LOGAN COUNTY ENGINEER" found in a monument box at Sta. 36+08.5 as reference on Logan County Engineer's Right of Way plans for Township Road #273 (50 feet wide) referenced as X-273, said pin marking the intersection of the centerline of County Road #5 with the northeastern terminus point of Township Road #273;

Thence South 71°09'58" West (assumed bearing) 791.13 feet, following the centerline of Township Road #273, to a railroad spike found at Sta. 28+45.8 as shown on said plans;

Thence South 76°09'53" West 363.76 feet, departing from the centerline of said Road, to a magnetic nail set and being South 72°59'27" West 1.43 feet from an iron pin set over a 2 inch iron pipe found 30 inches below the surface of said Road, said nail marking the northeast corner of said 57.55 acre tract;

Thence South 72°59'27" West 1027.01 feet, following the north line of said 57.55 acre tract, passing at 102.35 feet the centerline of said Road, to a magnetic nail set and marking the **place of beginning**;

Thence **South 21°40'43" East 897.83 feet**, departing from the north line of said 57.55 acre tract and entering said 57.55 acre tract, passing at 18.61 feet an iron pin set, to an iron pin set;

Thence **South 72°59'27" West 300.00 feet** to an iron pin set in the east line of Larry N. and Joyce A. Engle's original 198.000 acre tract described in Official Record 146, page 435;

Thence **North 21°40'43" West 897.83 feet**, following the west line of said 57.55 acre tract and the east line of said original 198.000 acre tract, passing at 875.15 feet an iron pin set, to a 5/8 inch iron pin found in said Road, said pin being South 21°40'43" East 2.38 feet from the intersection of the extended west line of said 57.55 acre tract with the centerline of said Road;

Thence **North 72°59'27" East 300.00 feet**, following the north line of said 57.55 acre tract, to the **place of beginning, containing 6.163 acres**, more or less, and being subject to all valid easements and restrictions of record. Of the above described 6.163 acre tract, 0.141 acre is within the Right of Way of Township Road #273.

The above description was prepared from a field survey made under the supervision of Paul R. Clapsaddle, Registered Surveyor #6140, during the month of September 2003. Bearings indicated herein are based on an assumed meridian with all others based on angles turned. Iron pins set are 5/8 inch by 30 inch reinforcing rods with caps marked "CLAPSADDLE RS #6140".

ATTEST:

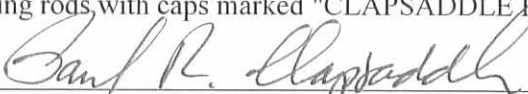
Paul R. Clapsaddle, R.S. #6140
19019 West Darby Road, Marysville, Ohio 43040
(937) 747-2599

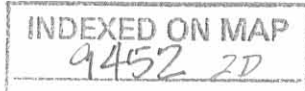

SURVEY FOR STEVEN GREGG

State of Ohio, County of Logan, Township of Rushcreek,
 V.M.S. 3326, being part of Steven R. and Bonnie L. Gregg's
 57.55 acre tract described in Official Record 105, page 556

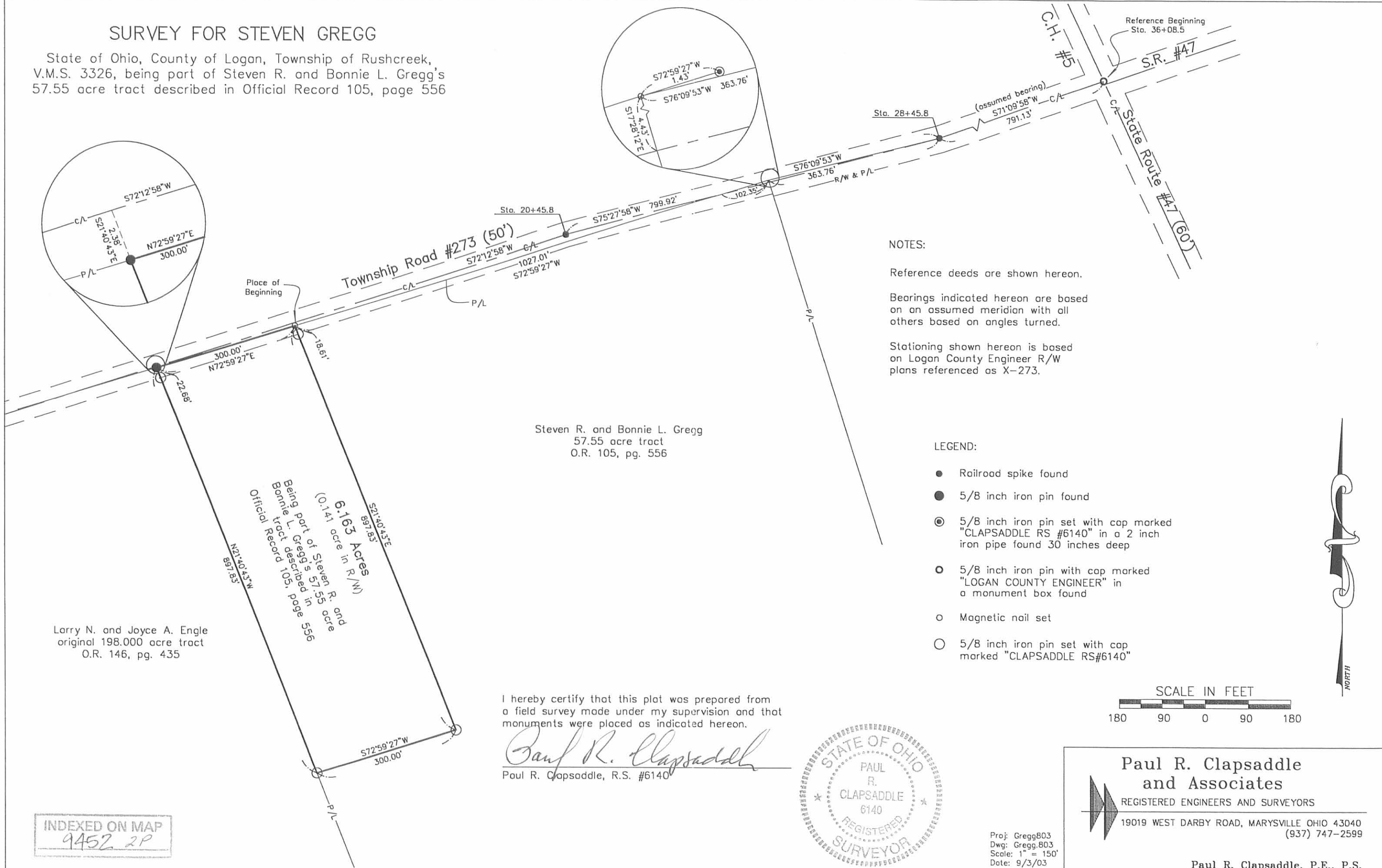
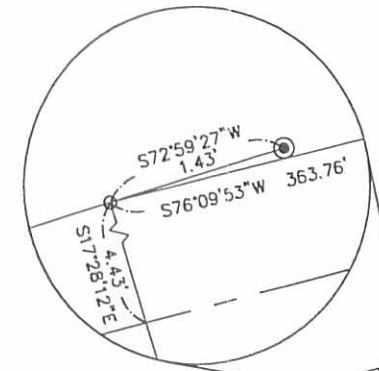
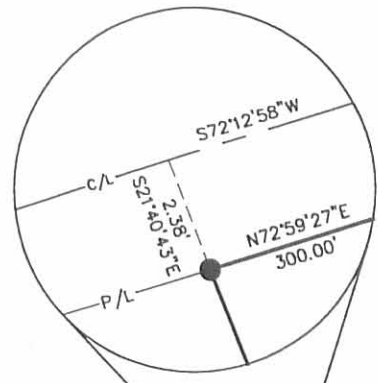

Steven R. and Bonnie L. Gregg
 57.55 acre tract
 O.R. 105, pg. 556

Larry N. and Joyce A. Engle
 original 198.000 acre tract
 O.R. 146, pg. 435

Being part of Steven R. and
 Bonnie L. Gregg's 57.55 acre
 tract described in
 Official Record 105, page 556
6.163 Acres
 (0.141 acre in R/W)

INDEXED ON MAP
 9452 2P

I hereby certify that this plat was prepared from
 a field survey made under my supervision and that
 monuments were placed as indicated hereon.

Paul R. Clapsaddle
 Paul R. Clapsaddle, R.S. #6140



NOTES:

Reference deeds are shown hereon.

Bearings indicated hereon are based
 on an assumed meridian with all
 others based on angles turned.

Stationing shown hereon is based
 on Logan County Engineer R/W
 plans referenced as X-273.

LEGEND:

- Railroad spike found
- 5/8 inch iron pin found
- ⊙ 5/8 inch iron pin set with cap marked "CLAPSADDLE RS #6140" in a 2 inch iron pipe found 30 inches deep
- 5/8 inch iron pin with cap marked "LOGAN COUNTY ENGINEER" in a monument box found
- Magnetic nail set
- 5/8 inch iron pin set with cap marked "CLAPSADDLE RS#6140"



Paul R. Clapsaddle and Associates
 REGISTERED ENGINEERS AND SURVEYORS
 19019 WEST DARBY ROAD, MARYSVILLE OHIO 43040
 (937) 747-2599

Paul R. Clapsaddle, P.E., P.S.

Proj: Gregg803
 Dwg: Gregg.803
 Scale: 1" = 150'
 Date: 9/3/03

SURVEY FOR STEVE GREGG

45.987 Acres

March 17, 2004

The following described 45.987 acre tract is situated in the State of Ohio, County of Logan, Township of Rushcreek, Township of Jefferson, V.M.S. 3326, being all of the remainder of Steven R. and Bonnie L. Gregg's original 57.55 acre tract described in Official Record 105, page 556, said 45.987 acre tract being more particularly described as follows:

Beginning for reference at a 5/8 inch iron pin with cap marked "OHIO DOT SURVEY PT" in a monument box found in the centerline of State Route #47 at P.I. Sta. 1056+01.62 as shown on Logan County Engineer Right of Way plans for State Route #47, referenced as L-44, said pin also marking the northern terminus point of the centerline of State Route #533;

Thence South 72°47'11" West (assumed bearing) 996.79 feet, following the centerline of State Route #47, to a railroad spike found at the southeast corner of said original 57.55 acre tract and at the southwest corner of Carl and Rosetta Burkholder's 1.022 acre tract described in Official Record 567, page 648, said spike marking the **place of beginning**;

Thence **South 72°47'11" West 1180.54 feet**, continuing with the centerline of State Route #47 and following the south line of said original 57.55 acre tract, to a 5/8 inch iron bolt found at the southeast corner of John F. and Carolyn Jean Capen's 7.000 acre tract described in Official Record 148, page 399;

Thence **North 21°40'43" West 1097.58 feet**, departing from the centerline of said Road, following the west line of said original 57.55 acre tract and the east line of said 7.000 acre tract, departing from Jefferson Township, entering Rushcreek Township, and also following the east line of Larry N. and Joyce A. Engle's original 198.000 acre tract described in Official Record 146, page 435, passing at 29.12 feet an iron pin set, to a 5/8 inch iron pin found with cap marked "CLAPSADDLE RS #6140" at the southwest corner of Scott P. and Carmen D. Levan's 6.163 acre tract described in Official Record 705, page 234 (said 6.163 acre tract formerly part of said original 57.55 acre tract);

Thence **North 72°59'27" East 300.00 feet**, departing from the east line of said original 198.000 acre tract and following the south line of said 6.163 acre tract and a north line of the remainder of said original 57.55 acre tract, to a 5/8 inch iron pin found with cap marked "CLAPSADDLE RS #6140";

Thence **North 21°40'43" West 897.83 feet**, passing at 879.22 feet a 5/8 inch iron pin found with cap marked "CLAPSADDLE RS #6140", to a magnetic nail found in Township Road #273;

Thence **North 72°59'27" East 512.74 feet**, following the north line of said original 57.55 acre tract, to a 5/8 inch iron pin found with cap marked "CLAPSADDLE RS #6140" at the northwest corner of Ronald S. Gill and Roberta Jean Kennedy-Gill's 5.036 acre tract described in Official Record 705, page 232 (said 5.036 acre tract formerly part of said original 57.55 acre tract);

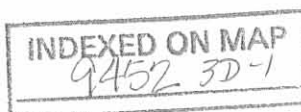

Thence **South 15°47'05" East 406.01 feet**, departing from the north line of said original 57.55 acre tract and Township Road #273, following the west line of said 5.036 acre tract and an east line of the remainder of said original 57.55 acre tract, passing at 11.64 feet a 5/8 inch iron pin found with cap marked "CLAPSADDLE RS #6140", to a 5/8 inch iron pin found with cap marked "CLAPSADDLE RS #6140";

Thence **North 76°22'51" East 527.38 feet**, following the south line of said 5.036 acre tract and a north line of the remainder of said original 57.55 acre tract, to a 5/8 inch iron pin found with cap marked "CLAPSADDLE RS #6140" in the west line of Carl Burkholder's 3.417 acre tract described in Official Record 404, page 608;

Thence **South 17°28'12" East 1547.53 feet**, following the east line of said original 57.55 acre tract and the west line of said 3.417 acre tract, Carl Burkholder's original 9.346 acre tract described in Official Record 382, page 278, Carl Burkholder's 5.389 acre tract described in Official Record 382, page 282, Carl Burkholder's original 10.200 acre tract described in Official Record 382, page 284, and said 1.022 acre tract, departing Rushcreek Township, entering Jefferson Township, and passing at 1517.45 feet a 5/8 inch iron pin found with cap marked 'LEE PS-6359', to the **place of beginning, containing 45.987 acres**, more or less, and being subject to all valid easements and restrictions of record.

Of the above described 45.987 acres, 0.991 acre is within the right of way of said Roads. Of the above described 45.987 acre tract, 37.737 acres are in Rushcreek Township and 8.250 acres are in Jefferson Township.

The above description was prepared from a field survey made under the supervision of Paul R. Clapsaddle, Registered Surveyor #6140, during the month of March 2003. Bearing indicated herein are based on an assumed meridian with all others based on angles turned. Iron pins set are 5/8 inch by 30 inch reinforcing rods with caps marked "CLAPSADDLE RS #6140".

ATTEST: Paul R. Clapsaddle
Paul R. Clapsaddle, R.S. #6140
19019 West Darby Road, Marysville, Ohio 43040
(937) 747-2599

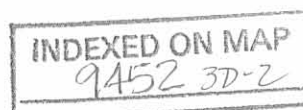

REC'D 4-15-04 SMY OK

SURVEY FOR STEVEN GREGG

State of Ohio, County of Logan, Township of Rushcreek, Township of Jefferson, V.M.S. 3326, being all of the remainder of Steven R. and Bonnie L. Gregg's original 57.55 acre tract described in Official Record 105, page 556

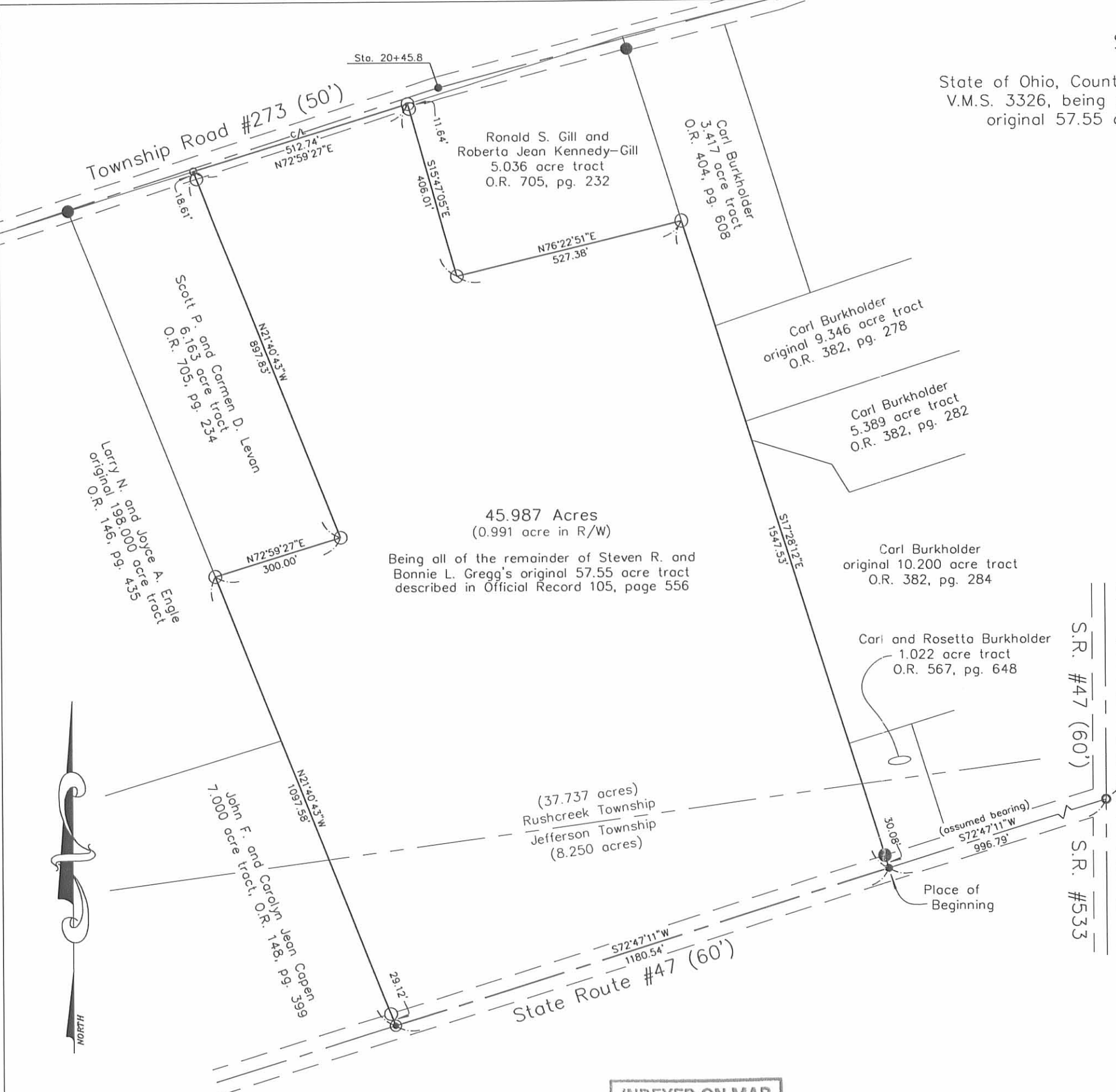

NOTES:

Reference deeds are shown hereon.

Bearings indicated hereon are based on an assumed meridian with all others based on angles turned.

Stationing shown hereon for S.R. #47 is based on Logan County Engineer R/W plans referenced as L-44.

Stationing shown hereon for T.R. #273 is based on Logan County Engineer R/W plans referenced as X-273.

LEGEND:

- Railroad spike found
- 5/8 inch iron pin found with cap marked "LEE PS-6359"
- ⊙ 5/8 inch iron bolt found
- 5/8 inch iron pin with cap marked "OHIO DOT SURVEY PT" in a monument box found
- Magnetic nail set
- 5/8 inch iron pin set with cap marked "CLAPSADDLE RS#6140"

I hereby certify that this plot was prepared from a field survey made under my supervision and that monuments were placed as indicated hereon

Paul R. Clapsaddle

Paul R. Clapsaddle, R.S. #6140

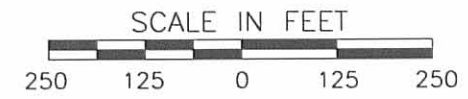

Paul R. Clapsaddle and Associates
 REGISTERED ENGINEERS AND SURVEYORS
 19019 WEST DARBY ROAD, MARYSVILLE OHIO 43040
 (937) 747-2599

Paul R. Clapsaddle, P.E., P.S.

Proj: Gregg803
Dwg: Gregg.304
Scale: 1" = 250'
Date: 3/17/04

INDEXED ON MAP
9452 3P

REV'D 6-25-08 SMY OK

Lee Surveying and Mapping Co., Inc.

Land Surveys • Topography • Subdivisions • Construction Layout

117 N. Madriver St.
Bellefontaine OH 43311



Phone: (937) 593-7335
Fax: (937) 593-7444

GREGG 24.448 ACRES

Lying in Virginia Military Survey 3326, Jefferson and Rushcreek Townships, Logan County, Ohio.

Being out of the Steven R. Gregg and Bonnie L. Gregg original 57.55 acre tract as deeded and described in Official Record 105, Page 556 in the Logan County Records of Deeds and being more particularly described as follows:

Commencing at a MAG nail set on the center-line of Ohio Route 47 (Variable widths) at Station 1044+35.00 (LOG-47-19.75, sheet 7 of 14).

THENCE, with the center-line of Ohio Route 47, S 84°-44'-21"W, a distance of 135.15 feet to a MAG nail set at THE TRUE POINT OF BEGINNING.

THENCE, with the center-line of Ohio Route 47, S 84°-44'-21"W, a distance of 875.55 feet to a 3/4 inch square iron bar found.

THENCE, with the east line of the John F. Capen and Carolyn Jean Capen 7.000 acre tract (O.R. 148, Pg. 399) and the east line of the Edward Schneider and Sharon R. Dedick 9.898 acre tract (O.R. 888, Pg. 186, Tract I), N 9°-43'-33"W, a distance of 1097.60 feet to a 5/8 inch iron rod found, passing a 5/8 inch iron rod found at 29.08 feet.

THENCE, with the lines of the Scott P. Levan and Carmen D. Levan 6.163 acre tract (O.R. 705, Pg. 234), the following two courses:

N 84°-56'-33"E, a distance of 300.00 feet to a 5/8 inch iron rod found.

N 9°-43'-33"W, a distance of 764.00 feet to a 5/8 inch iron rod set.

THENCE, S 65°-25'-16"E, a distance of 676.22 feet to a 5/8 inch iron rod set.

THENCE, S 3°-59'-03"W, a distance of 835.46 feet to a 5/8 inch iron rod set.

THENCE, S 56°-44'-28"W, a distance of 43.72 feet to a 5/8 inch iron rod set.

THENCE, S 5°-00'-41"W, a distance of 117.16 feet to a 5/8 inch iron rod set.

THENCE, S 45°-28'-36"E, a distance of 83.31 feet to a 5/8 inch iron rod set.

THENCE, S 6°-27'-01"E, a distance of 200.22 feet to a 5/8 inch iron rod set.

THENCE, S 47°-46'-09"E, a distance of 399.10 feet to the point of beginning, passing a 5/8 inch iron rod set at 358.40 feet.

Containing 24.448 acres of which 0.594 acre is within the highway right-of-way, 7.808 acres being in Jefferson Township and 16.640 acres being in Rushcreek Township.

The basis for bearings is center-line of Ohio Route 47, being S 84°-44'-21"W, and all other bearings are from angles and distances measured in a field survey by Lee Surveying and Mapping Co., Inc. on June 19, 2008

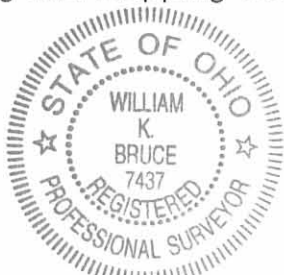

ORIGINAL STAMP IN GREEN

Description prepared by:

William K. Bruce
Professional Surveyor 7437
June 19, 2008

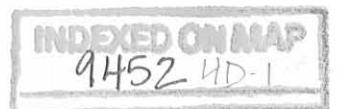

L-804068

REC'D 6-25-08 S.M.Y.O.U.

Lee Surveying and Mapping Co., Inc.

Land Surveys • Topography • Subdivisions • Construction Layout

117 N. Madriver St.
Bellefontaine OH 43311



Phone: (937) 593-7335
Fax: (937) 593-7444

GREGG 6.875 ACRES

Lying in Virginia Military Survey 3326, Jefferson and Rushcreek Townships, Logan County, Ohio.

Being out of the Steven R. Gregg and Bonnie L. Gregg original 57.55 acre tract as deeded and described in Official Record 105, Page 556 in the Logan County Records of Deeds and being more particularly described as follows:

Beginning at a MAG nail set on the center-line of Ohio Route 47 (Variable widths) at Station 1044+35.00 (LOG-47-19.75, sheet 7 of 14).

THENCE, with the center-line of Ohio Route 47, S 84°-44'-21"W, a distance of 106.10 feet to a MAG nail set.

THENCE, N 47°-34'-42"W, a distance of 409.54 feet to a 5/8 inch iron rod set, passing a 5/8 inch iron rod set at 40.57 feet.

THENCE, N 1°-47'-56"E, a distance of 273.24 feet to a 5/8 inch iron rod set.

THENCE, N 21°-44'-28"E, a distance of 66.84 feet to a 5/8 inch iron rod set.

THENCE, N 69°-53'-51"E, a distance of 91.87 feet to a 5/8 inch iron rod set.

THENCE, N 87°-06'-39"E, a distance of 396.41 feet to a 5/8 inch iron rod set.

THENCE, with the west line of the Troy Gibson and Kelly Gibson 9.178 acre tract (O.R. 716, Pg. 156), S 5°-30'-27"E, a distance of 343.68 feet to a 5/8 inch iron rod found.

THENCE, with the west line of the Troy Gibson and Kelly Gibson 1.022 acre tract (O.R. 749, Pg. 34, Tract I), S 5°-31'-45"E, a distance of 246.99 feet to a 5/8 inch iron rod set.

THENCE, with the lines of the State of Ohio, Department of Transportation 0.162 acre tract (O.R. 809, Pg. 623), the following three courses:

S 79°-11'-53"W, a distance of 155.35 feet to a 5/8 inch iron rod set.

S 66°-18'-17"W, a distance of 15.81 feet to a 5/8 inch iron rod set.

S 5°-15'-39"E, a distance of 30.00 feet to the point of beginning.

Containing 6.875 acres of which 0.082 acre is within the highway right-of-way, 3.359 acres being in Jefferson Township and 3.516 acres being in Rushcreek Township.

The basis for bearings is center-line of Ohio Route 47, being S 84°-44'-21"W, and all other bearings are from angles and distances measured in a field survey by Lee Surveying and Mapping Co., Inc. on June 19, 2008



ORIGINAL STAMP IN GREEN

Description prepared by:

William K. Bruce

William K. Bruce
Professional Surveyor 7437
June 19, 2008



L-804068

REC'D 6-25-08 SWM OK

TOWNSHIP ROAD 273

LEGEND

- 5/8 INCH IRON ROD SET
- 5/8 INCH IRON ROD FOUND
- ⊠ 3/4 SQUARE BAR FOUND
- MAG NAIL SET

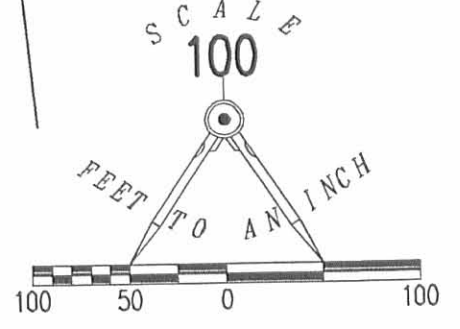

A SURVEY OF TWO TRACTS OUT OF THE
STEVEN R. GREGG AND BONNIE L. GREGG
ORIGINAL 57.55 ACRE TRACT
OFFICIAL RECORD 105, PAGE 556
VIRGINIA MILITARY SURVEY 3326
JEFFERSON AND RUSHCREEK TOWNSHIP
LOGAN COUNTY, OHIO

SCOTT P. LEVAN AND CARMEN D. LEVAN
6.163 ACRE TRACT
O.R. 705, PG. 234

EDWARD SCHNEIDER AND SHARON R. DEDICK
9.898 ACRE TRACT
O.R. 888, PG. 186
TRACT 1

N 09°43'33" W
764.00'

S 65°25'16" E
676.22'

N 84°56'33" E
300.00'

S 03°59'03" W
835.46'

STEVEN R. GREGG AND BONNIE L. GREGG
ORIGINAL 57.55 ACRE TRACT
O.R. 105, PG. 556

24.448 ACRES
OF WHICH 0.594 ACRE IS WITHIN THE HIGHWAY
RIGHT-OF-WAY.

43.72'
S 56°44'28" W

117.16'

S 05°00'41" W
83.31'

S 45°28'36" E

N 01°47'56" E
273.24'

N 21°44'28" E
66.84'

N 69°53'51" E
91.87'

N 87°06'39" E
396.41'

6.875 ACRES
OF WHICH 0.082 ACRE IS WITHIN THE HIGHWAY
RIGHT-OF-WAY.

TROY GIBSON AND KELLY GIBSON
9.178 ACRE TRACT
O.R. 716, PG. 156

S 05°30'27" E
343.68'

RUSHCREEK TOWNSHIP
JEFFERSON TOWNSHIP

(16.640 AC.)
(7.808 AC.)

(3.516 AC.)
(3.359 AC.)

N 09°43'33" W
1097.80'

TROY GIBSON AND KELLY GIBSON
1.022 ACRE TRACT
O.R. 749, PG. 34
TRACT 1

S 05°31'45" E
246.99'

JOHN F. CAPEN AND CAROLYN JEAN CAPEN
7.000 ACRE TRACT
O.R. 148, PG. 399

STATE OF OHIO,
DEPARTMENT OF
TRANSPORTATION
0.162 ACRE TRACT
O.R. 809, PG. 623

STA. 1044+35.00
LOG-47-19.75
SHEET 7 OF 14

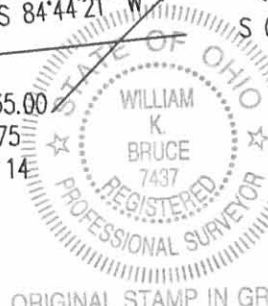

SURVEYED BY:

William K. Bruce
WILLIAM K. BRUCE
PROFESSIONAL SURVEYOR 7437
JUNE 19, 2008

ORIGINAL STAMP IN GREEN

COPYRIGHT 2008 BY:

LEE SURVEYING & MAPPING CO., INC.
117 North Modriver Street
BELLEFONTAINE, OHIO 43311
(937) 593-7335
surveys@lsmcinc.us

ADW D0608 804068 L-804068-2

47

(VARIABLE WIDTHS)

2 WORKING DAYS
BEFORE YOU DIG
CALL TOLL FREE 800-362-2764
OHIO UTILITIES PROTECTION SERVICE

INDEXED ON MAP
9452 4P

Lee Surveying and Mapping Co., Inc.

Land Surveys • Topography • Subdivisions • Construction Layout

117 N. Madriver St.
Bellefontaine OH 43311



Phone: (937) 593-7335
Fax: (937) 593-7444

GREGG 14.504 ACRES

Lying in Virginia Military Survey 3326, Jefferson and Rushcreek Townships, Logan County, Ohio.

Being out of the Steven R. Gregg and Bonnie L. Gregg original 57.55 acre tract as deeded and described in Official Record 105, Page 556 in the Logan County Records of Deeds and being more particularly described as follows:

Commencing at a MAG nail set on the center-line of Ohio Route 47 (Variable widths) at Station 1044+35.00 (LOG-47-19.75, sheet 7 of 14).

THENCE, with the center-line of Ohio Route 47, S 84°-44'-21"W, a distance of 106.10 feet to a MAG nail set at the TRUE POINT OF BEGINNING.

THENCE, with the center-line of Ohio Route 47, S 84°-44'-21"W, a distance of 29.05 feet to a MAG nail set.

THENCE, N 47°-46'-09"W, a distance of 399.10 feet to a 5/8 inch iron rod set, passing a 5/8 inch iron rod set at 40.70 feet.

THENCE, N 06°-27'-01"W, a distance of 200.22 feet to a 5/8 inch iron rod set.

THENCE, N 45°-28'-36"W, a distance of 83.31 feet to a 5/8 inch iron rod set.

THENCE, N 05°-00'-41"E, a distance of 117.16 feet to a 5/8 inch iron rod set.

THENCE, N 56°-44'-28"E, a distance of 43.72 feet to a 5/8 inch iron rod set.

THENCE, N 03°-59'-03"E, a distance of 835.46 feet to a 5/8 inch iron rod set.

THENCE, N 65°-25'-16"W, a distance of 676.22 feet to a 5/8 inch iron rod set.

THENCE, with the east line of the Scott P. Levan and Carmen D. Levan 6.163 acre tract (O.R. 705, Pg. 234), N 09°-43'-33"W, a distance of 133.83 feet to a MAG nail found on the center-line of Township Road 273, passing a 5/8 inch iron rod found at 103.73 feet.

THENCE, with the center-line of Township Road 273 (60 feet wide), N 84°-56'-28"E, a distance of 512.79 feet to a 5/8 inch iron rod found.

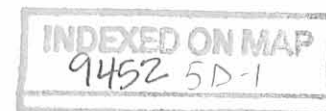

THENCE, with the lines of the Robert W. Kuehnle 5.036 acre tract (O.R. 818, Pg. 150), the following two courses:

Lee Surveying and Mapping Co., Inc.

Land Surveys • Topography • Subdivisions • Construction Layout

117 N. Madriver St.
Bellefontaine OH 43311



Phone: (937) 593-7335
Fax: (937) 593-7444

S 03°-49'-51"E, a distance of 406.01 feet to a 5/8 inch iron rod found, passing a 5/8 inch iron rod found at 30.01 feet.

N 88°-19'-35"E, a distance of 527.33 feet to a 5/8 inch iron rod found.

THENCE, with the west lines of the Mahlon Coblentz 3.417 acre tract (O.R. 718, Pg. 305, Tract 2), the James M. Lawlor 6.123 acre tract and 5.389 acre tract (O.R. 782, Pg. 238, Exhibit A, Page 3 and Page 2) and the Troy Gibson and Kelly Gibson 9.178 acre tract (O.R. 716, Pg. 156), S 05°-31'-05"E, a distance of 906.92 feet to a 5/8 inch iron rod set.

THENCE, S 87°-06'-39"W, a distance of 396.41 feet to a 5/8 inch iron rod set.

THENCE, S 69°-53'-51"W, a distance of 91.87 feet to a 5/8 inch iron rod set.

THENCE, S 21°-44'-28"W, a distance of 66.84 feet to a 5/8 inch iron rod set.

THENCE, S 01°-47'-56"W, a distance of 273.24 feet to a 5/8 inch iron rod set.

THENCE, S 47°-34'-42"E, a distance of 409.54 feet to the point of beginning, passing a 5/8 inch iron rod set at 368.97 feet.

Containing 14.504 acres, of which 0.020 acre is within the highway right-of-way. There is 0.286 acre within Jefferson Township and 14.218 acres within Rushcreek Township.

The basis for bearings is the center-line of Ohio Route 47, being S 84°-44'-21"W, and all other bearings are from angles and distances measured in a field survey by Lee Surveying and Mapping Co., Inc. on June 19, 2008.



Description prepared by:

A handwritten signature in black ink that reads 'William K. Bruce'.

William K. Bruce
Professional Surveyor 7437
July 1, 2008

804078



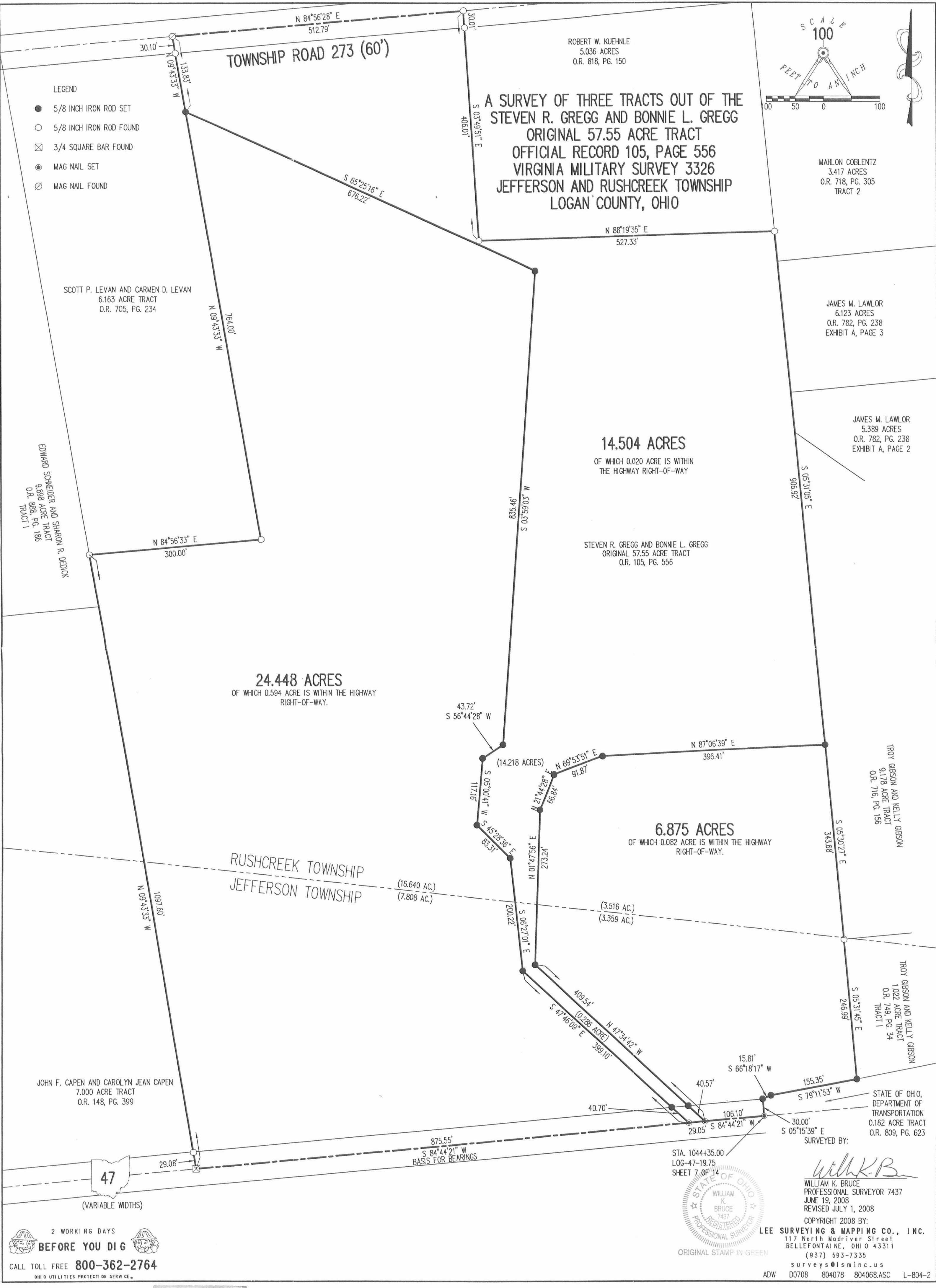

ROBERT W. KUEHNLE
5.036 ACRES
O.R. 818, PG. 150

A SURVEY OF THREE TRACTS OUT OF THE
STEVEN R. GREGG AND BONNIE L. GREGG
ORIGINAL 57.55 ACRE TRACT
OFFICIAL RECORD 105, PAGE 556
VIRGINIA MILITARY SURVEY 3326
JEFFERSON AND RUSHCREEK TOWNSHIP
LOGAN COUNTY, OHIO

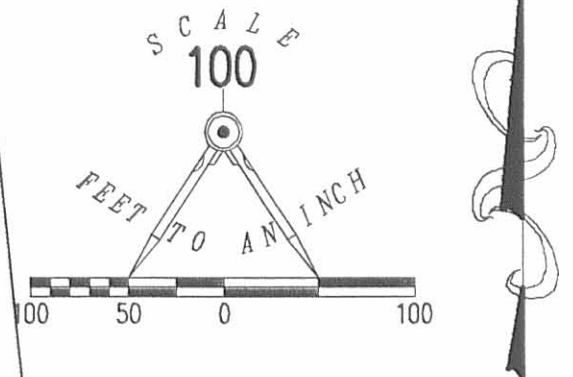

MAHLON COBLENTZ
3.417 ACRES
O.R. 718, PG. 305
TRACT 2

JAMES M. LAWLOR
6.123 ACRES
O.R. 782, PG. 238
EXHIBIT A, PAGE 3

JAMES M. LAWLOR
5.389 ACRES
O.R. 782, PG. 238
EXHIBIT A, PAGE 2

14.504 ACRES
OF WHICH 0.020 ACRE IS WITHIN
THE HIGHWAY RIGHT-OF-WAY

STEVEN R. GREGG AND BONNIE L. GREGG
ORIGINAL 57.55 ACRE TRACT
O.R. 105, PG. 556

24.448 ACRES
OF WHICH 0.594 ACRE IS WITHIN THE HIGHWAY
RIGHT-OF-WAY.

6.875 ACRES
OF WHICH 0.082 ACRE IS WITHIN THE HIGHWAY
RIGHT-OF-WAY.

TROY GIBSON AND KELLY GIBSON
9.178 ACRE TRACT
O.R. 716, PG. 156

TROY GIBSON AND KELLY GIBSON
1.022 ACRE TRACT
O.R. 749, PG. 34
TRACT 1

STATE OF OHIO,
DEPARTMENT OF
TRANSPORTATION
0.162 ACRE TRACT
O.R. 809, PG. 623

STA. 1044+35.00
LOG-47-19.75
SHEET 7 OF 14



William K. Bruce
WILLIAM K. BRUCE
PROFESSIONAL SURVEYOR 7437
JUNE 19, 2008
REVISED JULY 1, 2008
COPYRIGHT 2008 BY:
LEE SURVEYING & MAPPING CO., INC.
117 North Madriver Street
BELLEFONTAINE, OHIO 43311
(937) 593-7335
surveys@lsminc.us

- LEGEND
- 5/8 INCH IRON ROD SET
 - 5/8 INCH IRON ROD FOUND
 - ⊠ 3/4 SQUARE BAR FOUND
 - MAG NAIL SET
 - MAG NAIL FOUND

SCOTT P. LEVAN AND CARMEN D. LEVAN
6.163 ACRE TRACT
O.R. 705, PG. 234

EDWARD SCHAEFER AND SHARON R. DEDICK
9.898 ACRE TRACT
O.R. 888, PG. 186
TRACT 1

JOHN F. CAPEN AND CAROLYN JEAN CAPEN
7.000 ACRE TRACT
O.R. 148, PG. 399

RUSHCREEK TOWNSHIP
JEFFERSON TOWNSHIP

47
(VARIABLE WIDTHS)

2 WORKING DAYS
BEFORE YOU DIG
CALL TOLL FREE 800-362-2764
OHIO UTILITIES PROTECTION SERVICE

INDEXED ON MAP
9452 5P

ADW D0708 804078 804068.ASC L-804-2