

Rexer Survey Miami Township

Nov. 1951

18.87 Acres

The following described land in Miami Township, Logan County Ohio and being in Section 5 Town 3 Range 13

Being 18.87 acres off of the South end of a 49.39 acre tract now in the name of Winnie Doan Rexer the 18.87 acres being more fully described as follows Beginning at an iron in the center of County Road Number 65 at the N.W. corner of Forest T. Gross 80.00 acre tract and said beginning point being station 94 plus 15.5 of said Road Number 65 as shown in Logan County Engineer's Book 685 page 24 thence with the center of Road Number 65 N. $6^{\circ} - 00'$ E. 1196.5 feet to an iron the last described line passing the center of of a Pratt truss bridge over Stoney Creek at 411.4 feet thence S. $82^{\circ} - 06'$ E. 690.0 feet to a point in the west line of Chas. Notestine's 101.87 acre tract said point being S. $5^{\circ} - 37'$ W. ^{472.0 feet} from a large concrete post at the N.W. corner of said Notestine tract thence with the west side of said Notestine tract S. $5^{\circ} - 37'$ W. 1174.0 feet to a large concrete post in the North line of Forest T. Gross 80.00 acre tract the last described line passing a large concrete post on line at 430.0 feet and also passing a large square wood post on line at 816.0 feet thence with the North line of said Gross 80.00 acre tract N. $84^{\circ} - 04'$ W. 698.0 feet to the place of beginning the last described line passing the center of ~~Stoney~~ Stoney Creek at 172.0 feet said tract containing 18.87 acres.

cc
E.K. Core,
Logan County Engineer.

3113 ID

INDEXED ON MAP

REC'D 7-30-09 SWY OK

Lee Surveying and Mapping Co., Inc.

Land Surveys • Topography • Subdivisions • Construction Layout

117 N. Madriver St.
Bellefontaine OH 43311



Phone: (937) 593-7335
Fax: (937) 593-7444
surveys@lsminc.us

WEEKS, TRUSTEE 40.00 FEET WIDE INGRESS/EGRESS EASEMENT

Lying in Section 5, Town 3, Range 13, Miami Township, Logan County, Ohio.

Being a 40.00 feet wide ingress/egress easement over a portion of the Mary J. Weeks, Trustee, 18.87 acre tract as deeded and described in Official Record 628, Page 225, Tract II of the Logan County Records of Deeds and being more particularly described as follows:

Commencing on a 1 inch iron bar found on the center-line of County Highway 65 at Station 94+15.45 (Logan County Engineer's Field Book 685, Page 24) on the south line of the northwest quarter of Section 5.

THENCE, with the center-line of County Highway 65 (60 feet wide), N 06°-00'-00"E, a distance of 603.00 feet to a MAG nail set at the TRUE POINT OF BEGINNING.

Thence, with the center-line of the said 40.00 feet wide ingress/egress easement, the following four courses:

S 70°-08'-53"E, a distance of 273.80 feet to a 5/8 inch iron rod set.

S 63°-53'-13"E, a distance of 318.31 feet to a 5/8 inch iron rod set.

S 27°-31'-45"E, a distance of 95.30 feet to a 5/8 inch iron rod set.

S 02°-24'-30"W, a distance of 347.43 feet to a 5/8 inch iron rod set on the south line of the northwest quarter of Section 5 at the terminus of this easement.

The sidelines of said easement to be shortened or prolonged to meet at angle point intersections.

The basis for bearings is the center-line of County Highway 65, being N 06°-00'-00"E, and all other bearings are from angles and distances measured in a field survey by Lee Surveying and Mapping Co., Inc. on July 27, 2009.



ORIGINAL STAMP IN GREEN

Description prepared by:

William K. Bruce
Professional Surveyor 7437
July 28, 2009

4824079

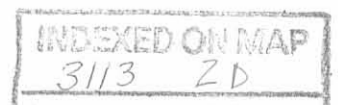

REC'D 7-30-09 8:44 AM

SECTION 6, TOWN 3, RANGE 13
SECTION 5, TOWN 3, RANGE 13

N 06°00'00" E
2115.14'

COUNTY HIGHWAY 65 (60')
(BASIS FOR BEARINGS)
N 06°00'00" E
603.00'

S 70°08'53" E
273.80'

S 63°53'13" E
318.31'

40' INGRESS/EGRESS
EASEMENT

MARY J. WEEKS, TRUSTEE
18.87 ACRES
O.R. 628, PG. 225
TRACT II

MARY J. WEEKS, TRUSTEE
80 ACRES
O.R. 628, PG. 225
TRACT I

639.14'
N 84°09'43" W

MARY J. WEEKS, TRUSTEE
80 ACRES
O.R. 628, PG. 225
TRACT I

S 27°31'45" E
95.30'

S 02°24'30" W
347.43'

57.25'

QUARTER SECTION LINE

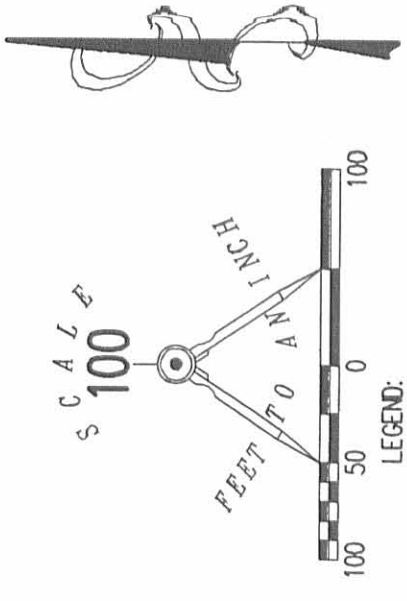

- LEGEND:
- 1 INCH IRON BAR FOUND
 - ⊕ 12 INCH CONCRETE POST FOUND
 - MAG NAIL SET
 - 5/8 INCH IRON ROD SET

**SURVEY OF A 40.00 FEET WIDE
INGRESS/EGRESS EASEMENT OVER THE
MARY J. WEEKS, TRUSTEE
18.87 ACRE TRACT
OFFICIAL RECORD 628, PAGE 225
TRACT II
SECTION 5, TOWN 3, RANGE 13
MIAMI TOWNSHIP
LOGAN COUNTY, OHIO**

SURVEYED BY:



William K. Bruce
WILLIAM K. BRUCE
PROFESSIONAL SURVEYOR 7437
JULY 27, 2009

ORIGINAL STAMP IN GREEN

COPYRIGHT 2009 BY:
LEE SURVEYING & MAPPING CO., INC.
117 North Madriver Street
BELLEFONTAINE, OHIO 43311
(937) 593-7335
surveys@lsmi.com
KSS D0709 4824079 L-4824-3

STATION 94+15.45
(LOGAN COUNTY ENGINEER'S
FIELD BOOK 685, PAGE 24)

2 WORKING DAYS
BEFORE YOU DIG
CALL TOLL FREE **800-362-2764**
OHIO UTILITIES PROTECTION SERVICE.

INDEXED ON MAP
3113 ZP