



Lee Surveying and Mapping Co., Inc.



Farm Surveys • Lot Surveys • Topography • Subdivisions • Construction Layout

117 NORTH MADRIVER STREET
BELLEFONTAINE, OHIO 43311

(937) 593-7335
FAX (937) 593-7444

ZIESSLER 30.368 ACRES

Lying in Sections 26, 27, 32 and 33, Town 4, Range 14, City of Bellefontaine, Lake and Liberty Townships, Logan County, Ohio.

Being out of the John J. Ziessler and Doris A. Ziessler original 103.13 acre tract as deeded and described in Volume 386, Page 705 of the Logan County Records of Deeds and out of the John J. Ziessler and Doris A. Ziessler original 41.021 acre tract as deeded and described in Official Record 57, Page 985 of the Logan County Records of Deeds and being more particularly described as follows:

Beginning at a 5/8 inch iron rod found at the northwest corner of Lot 4886 and on the south right-of-way of Kristina Drive (60 feet wide).

THENCE, with the south right-of-way of Kristina Drive, S 86°-49'-09" E, a distance of 70.00 feet to a 5/8 inch iron rod found.

THENCE, with the west line of the Nilo Two Limited Partnership 10.002 acre tract (O.R. 243, Pg. 663) the following four courses:

S 3°-10'-51" W, a distance of 800.00 feet to a 5/8 inch iron rod set.

S 86°-26'-32" E, a distance of 309.15 feet to a 5/8 inch iron rod set.

N 30°-12'-14" E, a distance of 431.88 feet to a 5/8 inch iron rod found.

S 86°-26'-32" E, a distance of 100.00 feet to a 5/8 inch iron rod found.

THENCE, with the lines of the Lola Mae Park 44.23 acre tract (Vol. 306, Pg. 575) the following two courses:

S 2°-45'-17" W, a distance of 201.49 feet to a 5/8 inch iron rod set.

S 86°-29'-14" E, with the north line of Section 26, a distance of 569.27 feet to a 5/8 inch iron rod set.

THENCE, with the west line of the Richard Kimball 46.88 acre tract (O.R. 33, Pg. 76), S 4°-30'-00" E, a distance of 814.38 feet to a 5/8 inch iron rod found.

THENCE, with the north line of the Z & H Investments original 48.31 acre tract (O.R. 248, Pg. 75), N 86°-27'-01" W, a distance of 1566.41 feet to a 5/8 inch iron rod found.

THENCE, with the lines of the State of Ohio 2.289 acre tract (Vol. 399, Pg. 249) the following two courses:

N 3°-28'-21" E, a distance of 296.81 feet to a 5/8 inch iron rod found.

N 86°-34'-40" W, a distance of 19.09 feet to a 5/8 inch iron rod found.

THENCE, with the east line of the Brunner Companies Income Properties L.P. III, original 21.397 acre tract (O.R. 93, Pg. 484), N 1°-50'-48" E, a distance of 853.09 feet to a 5/8 inch iron rod found.

THENCE, with the south line of Lot 4885, S 86°-49'-09" E, a distance of 248.85 feet to a 5/8 inch iron rod found.

THENCE, with the east line of Lot 4885, N 3°-10'-51" E, a distance of 269.99 feet to the point of beginning.

Containing 30.368 acres. 3.203 acres of which 0.434 acre is part of Lot 4886 are in Section 27 out of the aforesaid 103.13 acre tract. 25.482 acres are in Section 26 out of the aforesaid original 41.021 acres. 1.256 acres are in Section 32 out of the said original 41.021 acre tract. 0.427 acre is in Section 33 out of the 103.13 acre tract.

The basis for bearings is the west line of the aforementioned 10.002 acre tract being S 3°-10'-51" W, and all other bearings are from angles and distances measured in a field survey by Lee Surveying and Mapping Co., Inc. on September 13, 1996 and February 17, 1997.



ORIGINAL STAMP IN GREEN

Description prepared by:

Jeffrey J. Lee
Professional Surveyor 6359
February 20, 1997

INDEXED ON MAP
4199 9D

L 2456

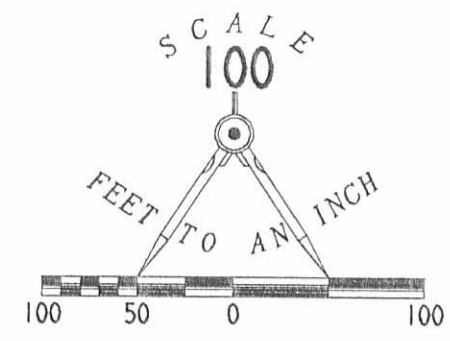

- LEGEND**
- 5/8" IRON ROD SET
 - 5/8" IRON ROD FOUND

REFERENCES
 JADO VILLE II, PLAT CABINET A, SLIDE 757-A
 LSM FILE NUMBERS L-1700, L-1371, L-2225

SURVEY OF 30.368 ACRES OUT OF THE
 JOHN ZIESSLER AND DORIS A. ZIESSLER
 ORIGINAL 41.021 ACRE TRACT
 OFFICIAL RECORD 57, PAGE 985
 AND THE
 JOHN J. ZIESSLER AND DORIS A. ZIESSLER
 ORIGINAL 103.13 ACRE TRACT
 VOLUME 386, PAGE 705
 INCLUDING PART OF
 LOT 4886, JADO VILLE II
 PLAT CABINET A, SLIDE 757-A
 SECTIONS 26, 27, 32, AND 33, TOWN 4, RANGE 14
 LAKE AND LIBERTY TOWNSHIPS
 CITY OF BELLEFONTAINE
 LOGAN COUNTY, OHIO

NOTE: THE EASEMENTS SHOWN ARE THE ONLY EASEMENTS THE SURVEYOR IS AWARE OF.
 LEE SURVEY & MAPPING CO., INC. DID NOT PERFORM A TITLE SEARCH ON THIS PROPERTY.

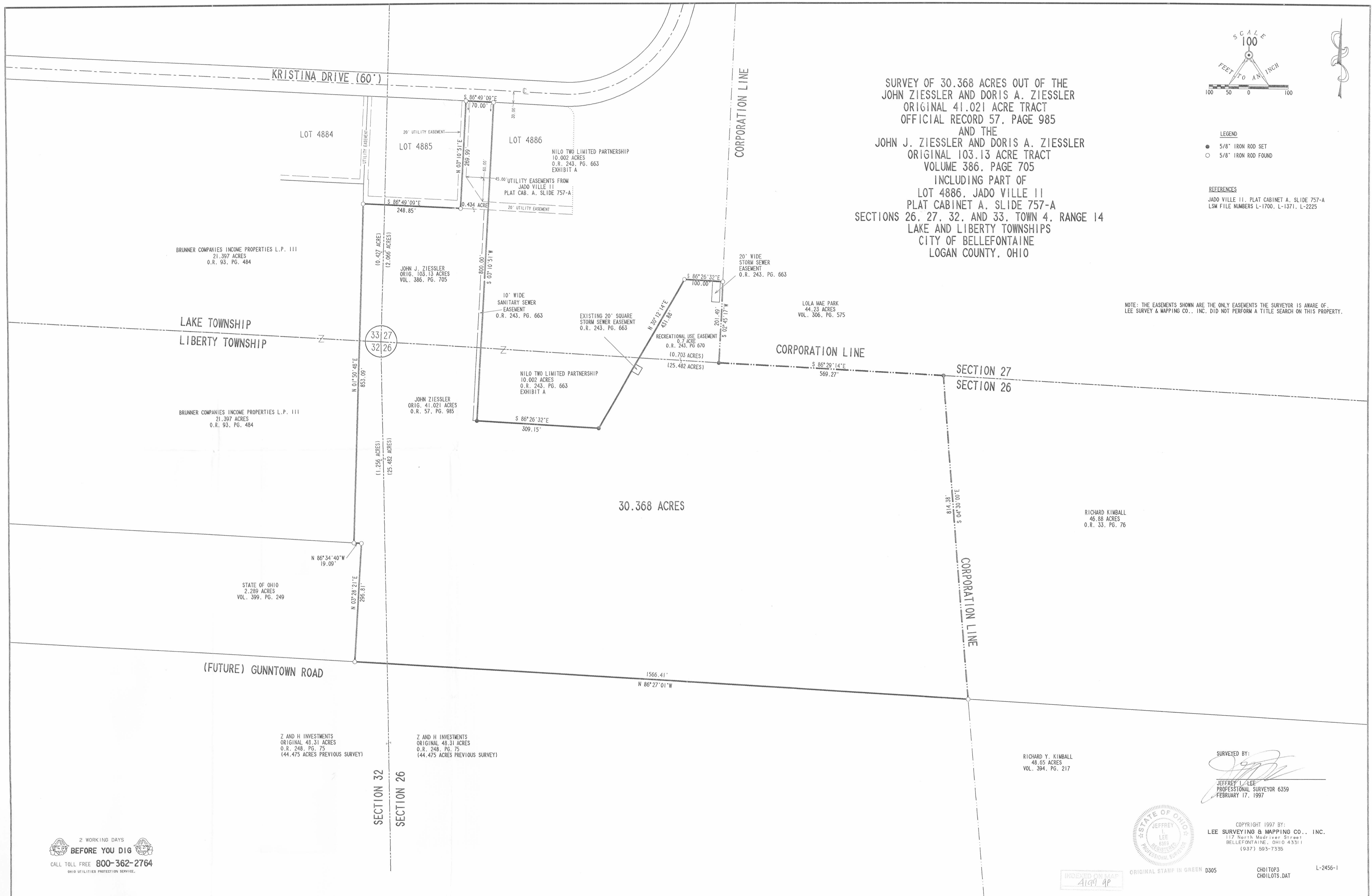

RICHARD Y. KIMBALL
 48.65 ACRES
 O.R. 394, PG. 217

SURVEYED BY:

 JEFFREY L. LEE
 PROFESSIONAL SURVEYOR 6359
 FEBRUARY 17, 1997



COPYRIGHT 1997 BY:
 LEE SURVEYING & MAPPING CO., INC.
 117 North Madison Street
 BELLEFONTAINE, OHIO 43311
 (937) 593-7335

INDEXED ON MAP
 4199 4P

ORIGINAL STAMP IN GREEN D305

CHOI10P3
 CH01LOTS.DAT

L-2456-1

2 WORKING DAYS
BEFORE YOU DIG
 CALL TOLL FREE 800-362-2764
 OHIO UTILITIES PROTECTION SERVICE

Z AND H INVESTMENTS
 ORIGINAL 48.31 ACRES
 O.R. 248, PG. 75
 (44.475 ACRES PREVIOUS SURVEY)

Z AND H INVESTMENTS
 ORIGINAL 48.31 ACRES
 O.R. 248, PG. 75
 (44.475 ACRES PREVIOUS SURVEY)

BRUNNER COMPANIES INCOME PROPERTIES L.P. III
 21.397 ACRES
 O.R. 93, PG. 484

BRUNNER COMPANIES INCOME PROPERTIES L.P. III
 21.397 ACRES
 O.R. 93, PG. 484

STATE OF OHIO
 2.289 ACRES
 VOL. 399, PG. 249

SECTION 32
 SECTION 26

30.368 ACRES

8-1-14

Lee Surveying and Mapping Co., Inc.



Land Surveys • Topography • Subdivisions • Construction Layout

117 N. Madriver St.
Bellefontaine OH 43311



Phone: (937) 593-7335
Fax: (937) 593-7444
surveys@lsminc.us

ZIESSLER 13.629 ACRES

Lying in Section 27, Town 4, Range 14, City of Bellefontaine, Lake Township, Logan County, Ohio.

Being all of the remainder of the John J. Ziessler and Doris A. Ziessler original 103.13 acre tract as deeded and described in Volume 386, Page 705 of the Logan County Records of Deeds and being more particularly described as follows:

Beginning on a 5/8 inch iron rod found on the southeast corner of Jado Ville (Plat Cabinet A, Slides 713A, 713B and 715A) on an east City of Bellefontaine Corporation line.

THENCE, with an east City of Bellefontaine Corporation line and the west lines of the Judith A. Park, Trustee, original 65.82 acre tract (O.R. 453, Pg. 193, Parcel 2, Tract 2), the Michael D. Fitzpatrick, etal, 49.22 acre tract and 6.22 acre tract (O.R. 1090, Pg. 258, Parcel III, Tract 1 and Tract 2) and the Judith A. Park, Trustee, 38.01 acre tract (O.R. 453, Pg. 193, Parcel I), S 02°-45'-59"W, a distance of 1399.68 feet to a 5/8 inch iron rod found.

THENCE, with the lines of the Deercreek Holdings, LLC, 10.002 acre tract (O.R. 1035, Pg. 778, Parcel I), the following two courses:

N 86°-26'-06"W, a distance of 231.69 feet to a 5/8 inch iron rod found.

With a curve to the right, having a central angle of 40°-42'-27", a radius of 310.00 feet, an arc length of 220.25 feet, a chord bearing S 68°-19'-58"W, a distance of 215.65 feet to a 5/8 inch iron rod set on the south right-of-way of Kristina Drive.

THENCE, with the east termination line of Kristina Drive (60 feet wide), N 01°-18'-49"W, a distance of 60.00 feet to a 5/8 inch iron rod found.

THENCE, with the north right-of-way of Kristina Drive, the following two courses:

With a curve to the right, having a central angle of 04°-30'-08", a radius of 250.00 feet, an arc length of 19.65 feet, a chord bearing N 89°-03'-45"W, a distance of 19.64 feet to a 5/8 inch iron rod found.

N 86°-50'-57"W, a distance of 36.16 feet to a 5/8 inch iron rod found.

THENCE, with the east line of the Autumn Woods Condominiums (Plat Cabinet B, Slide 84B), N 02°-38'-20"E, a distance of 671.58 feet to a 5/8 inch iron rod found.

THENCE, with the lines of the Highpoint Holdings LLC 10.881 acre tract (O.R. 892, Pg. 804), the following three courses:

S 84°-46'-18"E, a distance of 159.75 feet to a 5/8 inch iron rod found.

N 00°-15'-18"W, a distance of 711.29 feet to a 5/8 inch iron rod found.

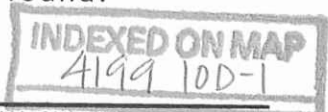

Lee Surveying and Mapping Co., Inc.

Land Surveys • Topography • Subdivisions • Construction Layout

117 N. Madriver St.
Bellefontaine OH 43311



Phone: (937) 593-7335
Fax: (937) 593-7444
surveys@lsmcinc.us

With a curve to the right, having a central angle of $27^{\circ}-53'-47''$, a radius of 50.00 feet, an arc length of 24.34 feet, a chord bearing $N 14^{\circ}-10'-29''E$, a distance of 24.10 feet to a $\frac{3}{4}$ inch iron pipe found.

THENCE, with an east line of the said 10.881 acre tract and an east line of The City of Bellefontaine, Ohio 1.004 acre tract (O.R. 730, Pg. 967), $N 28^{\circ}-07'-24''E$, a distance of 68.86 feet to a $\frac{5}{8}$ inch iron rod set.

THENCE, with the terminus of Kristina Drive (60 feet wide), $S 61^{\circ}-58'-51''E$, a distance of 60.00 feet to a $\frac{5}{8}$ inch iron rod set on the southwest corner of Lot 4682 of aforesaid Jado Ville.

THENCE, with the south line of Lot 4682, $S 85^{\circ}-22'-05''E$, a distance of 279.07 feet to the point of beginning.

Containing 13.629 acres.

Property is subject to any and all previous easements and rights-of-way of record.

The basis for bearings is the south line of Lot 4682, being $S 85^{\circ}-22'-05''E$, and all other bearings are from angles and distances measured in a field survey by Lee Surveying and Mapping Co., Inc. on July 24, 2014.



ORIGINAL STAMP IN GREEN

Description prepared by:

A handwritten signature in black ink that reads 'William K. Bruce'.

William K. Bruce
Professional Surveyor 7437
July 25, 2014

57690714

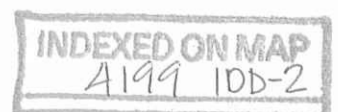

CURVE	DELTA ANGLE	RADIUS	ARC LENGTH	CHORD BEARING	CHORD LENGTH
C1	27°53'47"	50.00'	24.34'	N 14°10'29" E	24.10'
C2	40°42'27"	310.00'	220.25'	S 68°19'58" W	215.65'
C3	04°30'08"	250.00'	19.65'	N 89°03'45" W	19.64'

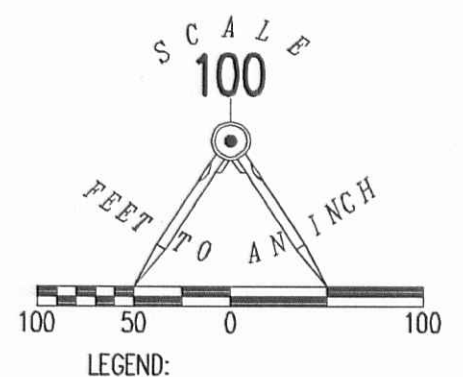

JUDITH A. PARK, TRUSTEE
 ORIGINAL 65.82 ACRES
 O.R. 453, PG. 193
 PARCEL 2, TRACT 2

HIGHPOINT HOLDINGS LLC
 10.881 ACRES
 O.R. 892, PG. 804

13.629 ACRES
 JOHN J. ZIESSLER AND
 DORIS A. ZIESSLER
 ORIGINAL 103.13 ACRES
 VOL. 386, PG. 705

MICHAEL D. FITZPATRICK, ETAL
 49.22 ACRES
 O.R. 1090, PG. 258
 PARCEL III, TRACT 1

AUTUMN WOODS COMDOMINIUMS
 PLAT CABINET B, SLIDE 84B

6.22 ACRES
 O.R. 1090, PG. 258
 PARCEL III, TRACT 2

**SURVEY OF THE REMAINDER OF THE
 JOHN J. ZIESSLER AND
 DORIS A. ZIESSLER
 ORIGINAL 103.13 ACRE TRACT
 VOLUME 386, PAGE 705
 SECTION 27, TOWN 4, RANGE 14
 CITY OF BELLEFONTAINE
 LAKE TOWNSHIP
 LOGAN COUNTY, OHIO**

JUDITH A. PARK, TRUSTEE
 38.01 ACRES
 O.R. 453, PG. 193
 PARCEL I

DEERCREEK HOLDINGS, LLC
 10.002 ACRES
 O.R. 1035, PG. 778
 PARCEL I

SURVEYED BY:

 WILLIAM K. BRUCE
 PROFESSIONAL SURVEYOR 7437
 JULY 24, 2014



COPYRIGHT 2014 BY:
LEE SURVEYING & MAPPING CO
 117 North Medriver Street, INC.
 BELLEFONTAINE, OHIO 43311
 (937) 593-7335
 WWW.LSMINC.US
 surveys@lsminc.us

2 WORKING DAYS
BEFORE YOU DIG
 CALL TOLL FREE **800-362-2764**
 OHIO UTILITIES PROTECTION SERVICE

INDEXED ON MAP
 4199 10P

VICINITY MAP

OVERLAY MAP

KRISTINA DRIVE (60')

DEDICATION

KNOW BY ALL MEN BY THESE PRESENT THAT SOUTH TOWNE MEADOWS, LLC OWNER OF 30.368 ACRES OF LAND INDICATED ON THE ACCOMPANYING PLAT BY VIRTUE OF A DEED RECORDED AS OFFICIAL RECORD 316, PAGE 183 LOGAN COUNTY RECORDER'S OFFICE HAS AUTHORIZED THE PLATTING OF BRODY DRIVE THEREOF BY RESOLUTION OF ALL MEMBERS OF THE LLC AS INDICATED BY THEIR SIGNATURES BELOW AND DOES HEREBY DEDICATE BRODY DRIVE TO THE PUBLIC USE FOREVER. THE OWNERS ALSO DEDICATE TO THE CITY OF BELLEFONTAINE ALL RIGHTS OF EASEMENT NOTED ON THE PLAT OR OBTAINED BY THE OWNER BY SEPARATE INSTRUMENT. THEY WILL DIRECT THE SURVEYOR TO PLACE THE MONUMENTS SHOWN HEREON UPON COMPLETION OF THE CONSTRUCTION FOR WHICH SURETY IS POSTED.

WITNESS: *Jason E. Lee*
Jason E. Lee
PRINTED NAME
Jennifer J. Gattrelle
PRINTED NAME
STATE OF OHIO
COUNTY OF LOGAN
BEFORE ME A NOTARY PUBLIC IN AND FOR SAID STATE AND COUNTY PERSONALLY CAME CHOICE DEVELOPMENT CORPORATION THROUGH KAMAL SHOUBAYIB WHO ACKNOWLEDGES THAT HE SIGNED AS PRESIDENT AND BY AUTHORITY OF THE CORPORATION BOARD OF DIRECTORS AND WHO ACKNOWLEDGED THE SIGNING OF THE FOREGOING INSTRUMENT TO BE HIS VOLUNTARY ACT AND DEED FOR THE USE AND PURPOSES THEREIN EXPRESSED THIS 11th DAY OF February 1999

OWNERS:
SOUTH TOWNE MEADOWS, LLC BY CHOICE DEVELOPMENT CORPORATION AND KAMAL SHOUBAYIB, BEING ALL OF ITS MEMBERS
CHOICE DEVELOPMENT CORPORATION BY KAMAL SHOUBAYIB ITS PRESIDENT
Kamal H. Shoubayib
KAMAL SHOUBAYIB

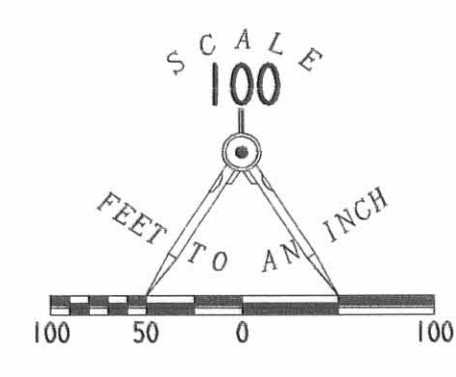

- LEGEND
- PROPOSED 5/8 INCH IRON ROD SET
 - ⊙ PROPOSED RAILROAD SPIKE SET
 - ⊙ 5/8 INCH IRON ROD SET
 - ⊙ RAILROAD SPIKE SET
 - ⊙ 5/8 INCH IRON ROD FOUND
 - ⊙ DRAINAGE EASEMENT
 - ⊙ WATER LINE EASEMENT
 - ⊙ SANITARY SEWER EASEMENT

- NOTES:
- THIS PLAT CONTAINS TWO PAGES
 - NO PERMANENT STRUCTURES OR PLANTINGS, ETC. SHALL BE PERMITTED IN THE EASEMENT AREAS.
 - THE AREA SHOWN HEREON IS IN FLOOD ZONE "C" PER THE FEDERAL EMERGENCY MANAGEMENT AGENCY FLOOD PANEL # 390772 0115 C, DATED MAY 15, 1985
 - THE CITY OF BELLEFONTAINE IS GRANTED INGRESS/EGRESS OVER THE PRIVATE STREETS TO SERVICE AND MAINTAIN THE DEDICATED EASEMENTS

IN TESTIMONY WHEREOF, I HAVE HEREUNTO SUBSCRIBED MY NAME AND AFFIXED MY OFFICIAL SEAL THIS 11th DAY OF February 1999
Kim M. McConnell
NOTARY PUBLIC
Kim M. McConnell
Notary Public, State of Ohio
My Commission Expires 6-5-2000

BEFORE ME A NOTARY PUBLIC IN AND FOR SAID STATE AND COUNTY PERSONALLY CAME KAMAL SHOUBAYIB INDIVIDUALLY WHO ACKNOWLEDGES THAT THE SIGNING OF THE FOREGOING INSTRUMENT TO BE HIS VOLUNTARY ACT AND DEED FOR THE USE AND PURPOSES THEREIN EXPRESSED THIS 11th DAY OF February 1999

IN TESTIMONY WHEREOF, I HAVE HEREUNTO SUBSCRIBED MY NAME AND AFFIXED MY OFFICIAL SEAL THIS 11th DAY OF February 1999
Kim M. McConnell
NOTARY PUBLIC
Kim M. McConnell
Notary Public, State of Ohio
My Commission Expires 6-5-2000

STREET DEDICATION PLAT OF BRODY DRIVE AND SOUTH TOWNE MEADOWS EASEMENTS DEDICATION, OUT OF THE SOUTH TOWNE MEADOWS LIMITED LIABILITY COMPANY ORIGINAL 30.368 ACRE TRACT OFFICIAL RECORD 316, PAGE 183 AND LOT 4886 OF JADO VILLE II PLAT CABINET A, SLIDES 757A AND 757B SECTION 26, 27, AND 32, TOWN 4, RANGE 14 CITY OF BELLEFONTAINE LAKE AND LIBERTY TOWNSHIPS LOGAN COUNTY, OHIO

RICHARD KIMBALL
46.85 ACRES
O.R. 33, PG. 76

APPROVALS

THE WITHIN STREETS ARE HEREBY APPROVED AND ACCEPTED FOR PUBLIC MAINTENANCE BY ORDINANCE NO. 99-87 RECORDED IN CITY COUNCIL'S RECORD BOOK ON THIS 24th DAY OF Aug. 1999
William W. Patterson
MAYOR, CITY OF BELLEFONTAINE
William W. Patterson
PRESIDENT, BELLEFONTAINE CITY COUNCIL
APPROVED THIS 28th DAY OF September 1999
Jason E. Lee
BELLEFONTAINE CITY ENGINEER
APPROVED THIS 28th DAY OF September 1999
Dana E. Zimmerman
CHAIRMAN, BELLEFONTAINE CITY PLANNING COMMISSION
APPROVED THIS 28th DAY OF September 1999
Vicki Youkam
CLERK, BELLEFONTAINE CITY COUNCIL
PREAPPROVAL Jan C. Hines 2-1-99
PLAT CHECKED Jan C. Hines 11-22-99
TRANSFERRED THIS 22nd DAY OF November 1999
Richard Y. Kimball
AUDITOR, LOGAN COUNTY, OHIO
RECORDED IN PLAT CABINET B, SLIDE 46B RECEIVED FOR RECORD AT 3:43 O'CLOCK PM THIS 22nd DAY OF November 1999
Carolyn Collins
RECORDER, LOGAN COUNTY, OHIO

SURVEYOR'S STATEMENT

THE ACCOMPANYING PLAT REPRESENTS STREET DEDICATION FOR BRODY DRIVE, SECTIONS 26, 27 AND 32, TOWN 4, AND RANGE 14, CITY OF BELLEFONTAINE, LAKE AND LIBERTY TOWNSHIP, LOGAN COUNTY, OHIO
THE STREET HAS AN AREA OF 1.917 ACRES OUT OF THE SOUTH TOWNE MEADOWS, LLC, ORIGINAL 30.368 ACRE TRACT AND LOT 4886 OF JADO VILLE II, OF WHICH 0.916 ACRE IS IN SECTION 27 WITH 0.372 ACRE IN LOT 4886, LAKE TOWNSHIP, 0.113 ACRE IS IN SECTION 26, AND 0.888 ACRE IS IN SECTION 32, LIBERTY TOWNSHIP.
ALL MEASUREMENTS ARE IN FEET AND DECIMALS OF A FOOT.
I HEREBY STATE THAT THE ACCOMPANYING PLAT IS A CORRECT REPRESENTATION OF BRODY DRIVE AS SURVEYED IN SEPTEMBER 1997, AND THAT ALL MONUMENTS AS SHOWN HEREON HAVE BEEN FOUND, SET, OR WILL BE SET UPON COMPLETION OF CONSTRUCTION AT A TIME AS DIRECTED BY THE PROPRIETORS.

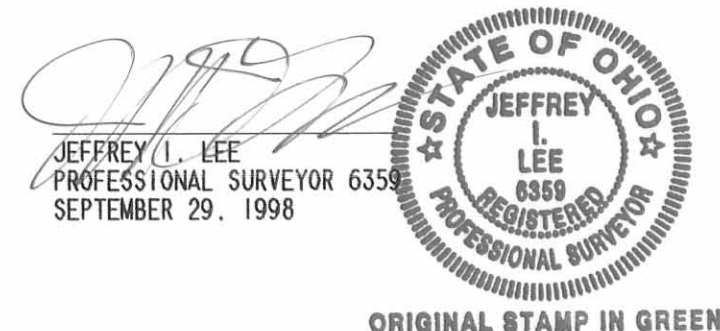

DEVELOPER
SOUTH TOWNE MEADOWS
SUITE 1412
TROY, MICHIGAN 48064
(248) 362-4150
COPYRIGHT 1998 BY:
LEE SURVEYING & MAPPING CO., INC.
117 North Madison Street
BELLEFONTAINE, OHIO 43311
(937) 593-7335

CURVE	DELTA ANGLE	RADIUS	ARC	TANGENT	CHORD	CHORD BEARING
C 1	10°00'00"	150.00'	26.18'	13.12'	26.15'	N 01°31'39"W
C 2	08°22'27"	150.00'	21.92'	10.98'	21.90'	N 02°20'26"W
C 3	43°21'56"	300.00'	227.06'	119.28'	221.68'	N 23°31'45"E
C 4	42°01'49"	300.00'	220.07'	115.25'	215.17'	N 24°11'45"E
C 5	89°55'22"	25.00'	39.24'	24.97'	35.33'	S 41°29'20"E
C 6	10°00'00"	175.00'	30.54'	15.31'	30.50'	S 01°31'39"E
C 7	08°22'27"	125.00'	18.27'	9.15'	18.25'	S 02°20'26"E
C 8	32°28'29"	275.00'	155.87'	80.09'	153.79'	S 18°05'03"W
C 9	42°01'49"	335.00'	245.74'	128.70'	240.27'	S 24°11'45"W
C 10	90°00'05"	20.00'	31.42'	20.00'	28.29'	S 48°10'52"W
C 11	42°01'49"	275.00'	201.73'	105.65'	197.24'	N 24°11'45"E
C 12	43°21'56"	325.00'	245.98'	129.22'	240.15'	N 23°31'45"E
C 13	9°34'31"	265.00'	44.29'	22.20'	44.24'	S 40°25'28"W

BRUNNER COMPANIES INCOME PROPERTY
11.049 ACRES
O.R. 93, PG. 484

STATE OF OHIO
2.289 ACRES
VOL. 399, PG. 249

STATE OF OHIO
5 ACRES
VOL. 206, PG. 2

FRISCH'S RESTAURANTS INC.
1.238 ACRES
O.R. 252, PG. 773

PAUL T. HUMBLE
AND JOHN J. ZIESSLER
44.475 ACRES
O.R. 332, PG. 700

PROPOSED GUNNTOWN ROAD (80')

DESCRIPTION

Lying in Sections 26, 27 and 32, Town 4, Range 14, City of Bellefontaine, Lake and Liberty Townships, Logan County, Ohio.
Being out of the South Towne Meadows, Limited Liability Company, original 30.368 acre tract and Lot 4886 of Jado Ville II, (Plat Cabinet A, Slides 757A and 757B), as deeded and described in Official Record 316, Page 183 of the Logan County Records of Deeds and being more particularly described as follows:
Beginning at a 5/8 inch iron rod found on the south right-of-way of Kristina Drive, 160 feet wide), at the northeast corner of Lot 4885 of Jado Ville II.
THENCE, with the south right-of-way of Kristina Drive, S 86°49'08" E, a distance of 60.00 feet to a 5/8 inch iron rod set.
THENCE, S 3°10'51" W, a distance of 319.75 feet to a 5/8 inch iron rod set.
THENCE, with a curve to the right having a central angle of 42°01'49", a radius of 335.00 feet, an arc length of 245.74 feet, and a chord bearing S 24°11'45"W a distance of 240.27 feet to a 5/8 inch iron rod set.
THENCE, S 45°12'43" W, a distance of 122.17 feet to a 5/8 inch iron rod set.
THENCE, with a curve to the left having a central angle of 9°34'31", a radius of 265.00 feet, an arc length of 44.29 feet, and a chord bearing S 24°11'45"W a distance of 44.24 feet to a 5/8 inch iron rod set.
THENCE, N 86°49'09" W, a distance of 11.76 feet to a 5/8 inch iron rod set.
THENCE, with a curve to the left having a central angle of 32°28'29", a radius of 275.00 feet, an arc length of 155.87 feet, and a chord bearing S 18°05'03"W, a distance of 153.79 feet to a 5/8 inch iron rod set.
THENCE, S 01°50'48" W, a distance of 148.19 feet to a 5/8 inch iron rod set.
THENCE, with a curve to the left having a central angle of 8°22'27", a radius of 125.00 feet, an arc length of 18.27 feet, and a chord bearing S 2°20'26" E, a distance of 18.25 feet to a 5/8 inch iron rod set.

THENCE, S 6°31'39" E, a distance of 109.41 feet to a 5/8 inch iron rod set.
THENCE, with a curve to the right having a central angle of 10°00'00", a radius of 175.00 feet, an arc length of 30.54 feet, and a chord bearing S 1°31'39"E a distance of 30.50 feet to a 5/8 inch iron rod set.
THENCE, S 3°28'21" W, a distance of 271.91 feet to a 5/8 inch iron rod set.
THENCE, with a curve to the left having a central angle of 89°55'22", a radius of 25.00 feet, an arc length of 39.24 feet, and a chord bearing S 41°29'20"E, a distance of 35.33 feet to a 5/8 inch iron rod set on the north line of Paul T. Humble et al 44.475 acre tract (O.R. 332, Pg. 700), set point also being the north right-of-way line of the proposed Gunntown Road.
THENCE, with the north line of the said 44.475 acre tract and the north line of the proposed Gunntown Road, (80 feet wide), N 86°27'01" W, a distance of 74.97 feet to a 5/8 inch iron rod found at the southeasterly corner of the State of Ohio 2.289 acre tract. (Vol. 399, Pg. 249).
THENCE, with the east line of the State of Ohio 2.289 acre tract (Vol. 399, Pg. 249), N 3°28'21" E, a distance of 296.81 feet to a 5/8 inch iron rod found.
THENCE, with the north line of the said 2.289 acre tract, N 86°34'40" W, a distance of 19.09 feet to a 5/8 inch iron rod found.
THENCE, with the east line of the Brunner Companies Income Property 11.049 acre tract (O.R. 93, Pg. 484), N 1°50'48" E, a distance of 303.14 feet to a 5/8 inch iron rod set.
THENCE, with a curve to the right having a central angle of 43°21'56", a radius of 325.00 feet, an arc length of 245.98 feet, and a chord bearing N 23°31'45" E a distance of 240.15 feet to a 5/8 inch iron rod set.
THENCE, N 45°12'43" E, a distance of 122.17 feet to a 5/8 inch iron rod set.

THENCE, with a curve to the left having a central angle of 42°01'49", a radius of 275.00 feet, an arc length of 201.73 feet, and having a chord bearing N 24°11'45"E a distance of 197.24 feet to a 5/8 inch iron rod set.
THENCE, with east line extended and the east line of Lot 4885, N 3°10'51" E, a distance of 319.75 feet to the point of beginning.
Containing 1.917 acres, of which, 0.916 acre is in Section 27 with 0.372 acre in Lot 4886, Lake Township, 0.113 acre is in Section 26, and 0.888 acre is in Section 32, Liberty Township.
The basis for bearings is the center-line of U.S. Route 68 and South Main Street, being N 4°30'00" W, and all other bearings are from angles and distances measured in a field survey by Lee Surveying and Mapping Co., Inc. on September 19, 1997.
Description prepared by Jeffrey I. Lee, Professional Surveyor 6359.

LEGEND

- PROPOSED 5/8 INCH IRON ROD SET
- 5/8 INCH IRON ROD FOUND
- ⊕ PROPOSED RAILROAD SPIKE SET
- ⊙ RAILROAD SPIKE SET

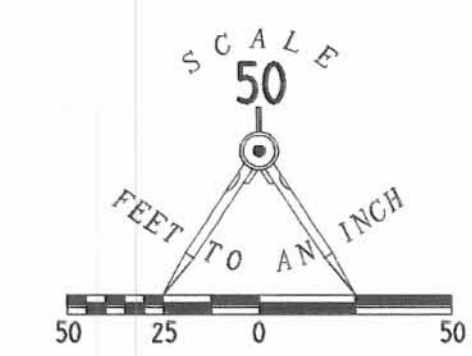

SECTION 27
SECTION 26

CURVE	DELTA ANGLE	RADIUS	ARC	TANGENT	CHORD	CHORD BEARING
C 2	40°08'47"	180.50'	126.47'	65.96'	123.90'	N 73°28'37"E
C 3	17°35'57"	80.50'	24.73'	12.46'	24.63'	S 05°15'00"E
C 4	10°00'00"	150.00'	26.18'	13.12'	26.15'	N 01°31'39"W
C 5	08°22'27"	150.00'	21.92'	10.98'	21.90'	N 02°20'26"W

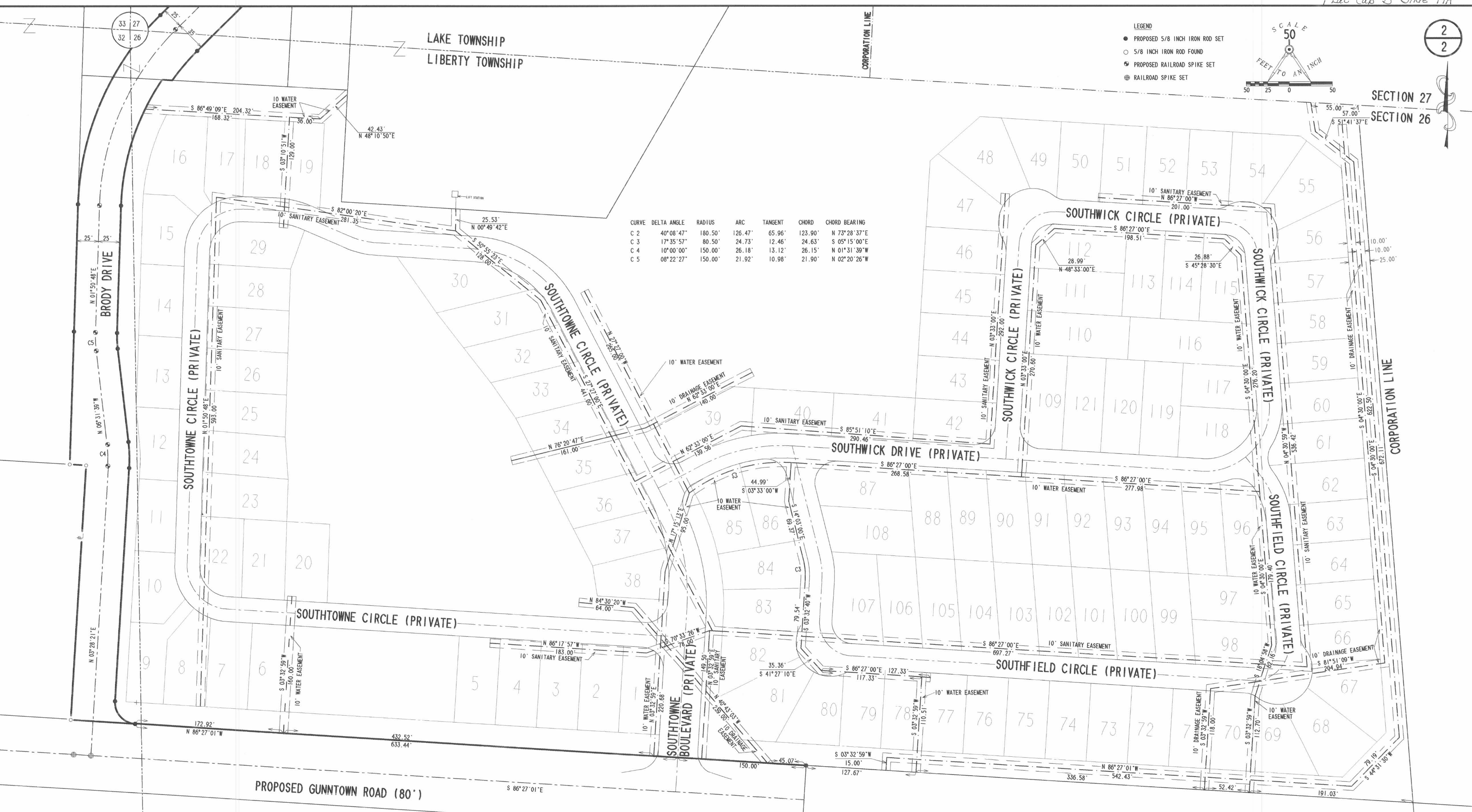

EASEMENT DEDICATION MAP OVER
THE SOUTH TOWNE MEADOWS
LIMITED LIABILITY COMPANY
30.368 ACRE TRACT
OFFICIAL RECORD 316, PAGE 183
SECTION 26 AND 32, TOWN 4, RANGE 14
CITY OF BELLEFONTAINE
LIBERTY TOWNSHIP
LOGAN COUNTY, OHIO

PAUL T. HUMBLE
AND JOHN J. ZIESSLER
44.475 ACRES
O.R. 332, PG. 700

DECEMBER 9, 1998
COPYRIGHT 1998 BY:
LEE SURVEYING & MAPPING CO., INC.
117 North Madison Street
BELLEFONTAINE, OHIO 43311
(937) 693-7335

D306 CHSTFPL2 L-2456
CHOILOTS.DAT 11/9/99

3-10-2022



INNOVATIVE IDEAS
EXCEPTIONAL DESIGN
UNMATCHED CLIENT SERVICE

JLH REALTY LLC AND STONE KEP CORPORATION 2.509 ACRES

Situate in the State of Ohio, Logan County, Lake Township, City of Bellefontaine and lying Section 27, Town 4, Range 14, and being out of the 13.629 acres as conveyed to JLH Realty LLC and Stone Kep Corporation by deed of record in Official Record 1394, Page 4626 (all records referenced herein refer to the Logan County Records of Deeds) and being more particularly described as follows:

BEGINNING at a 5/8 inch iron rebar found at the southerly corner common to said 13.629 acre tract and Autumn Woods Condominiums as recorded in Plat Cabinet B, Slide 84B, and being on the north right-of-way line of Kristina Drive (60 feet wide);

THENCE, North 04°-38'-35" East, a distance of 400.85 feet, with the line common to said 13.629 acre tract and Autumn Woods Condominiums, to a 5/8 inch iron rebar set (I.D. cap stamped "DLZ OHIO INC");

THENCE, with new division lines through said 13.629 acre tract, the following six (6) courses:

South 85°-21'-24" East, a distance of 318.33 feet to a 5/8 inch iron rebar set (I.D. cap stamped "DLZ OHIO INC");

South 04°-38'-35" West, a distance of 306.50 feet to a 5/8 inch iron rebar set (I.D. cap stamped "DLZ OHIO INC");

North 85°-21'-24" West, a distance of 178.17 feet to a 5/8 inch iron rebar set (I.D. cap stamped "DLZ OHIO INC");

South 04°-38'-36" West, a distance of 61.50 feet to a 5/8 inch iron rebar set (I.D. cap stamped "DLZ OHIO INC"): and

South 75°-55'-06" West, a distance of 57.69 feet to a 5/8 inch iron rebar set (I.D. cap stamped "DLZ OHIO INC");

South 69°-19'-45" West, a distance of 32.90 feet to a 5/8 inch iron rebar found at the northeast corner of the terminus of Kristina Drive (width varies);

THENCE, with lines common to said 13.629 acre tract and the north right-of-way lines of said Kristina Drive, the following two (2) courses:

With a curve to the right, having a delta angle of 04°-30'-12", a radius of 250.00 feet, an arc length of 19.65 feet, a chord bearing North 87°-05'-28" West, a distance of 19.64 feet to a 5/8 inch iron rebar found;





INNOVATIVE IDEAS
EXCEPTIONAL DESIGN
UNMATCHED CLIENT SERVICE

North 84°-50'-22" West, a distance of 36.16 feet to the **POINT OF BEGINNING.**

Containing 2.509 acres, more or less.

The bearings in the above description are based on the grid bearing of North 00°-29'-59" East, for the easterly right-of-way of Kristina Drive as determined by a GPS network of field observations performed in January, 2022 and are based upon the Ohio State Plane Coordinate System, North Zone, NAD83 (2011).

All rebar set are 5/8 inch in diameter and 30 inches in length, with a yellow cap stamped "DLZ OHIO INC."

I certify that this description is based upon a survey conducted under my direct supervision in January, 2022 and that it and the information contained herein are true and correct to the best of my knowledge.

DLZ Ohio, Inc.

Samuel L. Stiltner
Professional Surveyor No. 8364



2121-2184.00



✓ APPROVED

3-10-2022



INNOVATIVE IDEAS
EXCEPTIONAL DESIGN
UNMATCHED CLIENT SERVICE

JLH REALTY LLC AND STONE KEP CORPORATION ACCESS EASEMENT (0.112 ACRE)

Situate in the State of Ohio, Logan County, Lake Township, City of Bellefontaine and lying Section 27, Town 4, Range 14, and being an access easement over part of the 13.629 acres as conveyed to JLH Realty LLC and Stone Kep Corporation by deed of record in Official Record 1394, Page 4626 (all records referenced herein refer to the Logan County Records of Deeds) and being more particularly described as follows:

COMMENCE at 5/8 inch iron rebar found at the southerly corner common to said 13.629 acre tract and Autumn Woods Condominiums as recorded in Plat Cabinet B, Slide 84B, and being on the north right-of-way line of Kristina Drive (60 feet wide);

THENCE, North 04°-38'-35" East, a distance of 400.85 feet, with the line common to said 13.629 acre tract and Autumn Woods Condominiums, to a 5/8 inch iron rebar set (I.D. cap stamped "DLZ OHIO INC");

THENCE, with new division lines through said 13.629 acre tract, the following three (3) courses:

South 85°-21'-24" East, a distance of 318.33 feet to a 5/8 inch iron rebar set (I.D. cap stamped "DLZ OHIO INC");

South 04°-38'-35" West, a distance of 306.50 feet to a 5/8 inch iron rebar set (I.D. cap stamped "DLZ OHIO INC"); and

North 85°-21'-24" West, a distance of 149.17 feet to a point at the **TRUE POINT OF BEGINNING**;

THENCE, with lines of said access easement, the following ten (10) courses:

South 04°-38'-36" West, a distance of 54.94 feet to a point of curvature;

With a curve to the left, non-tangent to the previous course, having a delta angle of 26°-41'-03", a radius of 25.00 feet, an arc length of 11.64 feet and a chord bearing South 28°-19'-50" West, a distance of 11.54 feet to a point of tangency;

South 14°-59'-14" West, a distance of 2.26 feet to a point of curvature:

With a curve to the right, having a delta angle of 74°-28'-03", a radius of 72.00 feet, an arc length of 93.58 feet and a chord bearing South 43°-48'-41" West, a distance of 87.13 feet to a point;

INDEXED ON MAP
4199



INNOVATIVE IDEAS
EXCEPTIONAL DESIGN
UNMATCHED CLIENT SERVICE

With a curve to the right, having a delta angle of 02°-18'-14", a radius of 300.00 feet, an arc length of 12.06 feet and a chord bearing South 82°-11'-49" West, a distance of 12.06 feet to a point of tangency;

North 06°-40'-42" West, a distance of 40.00 feet to a point of curvature:

With a curve to the left, non-tangent to the previous course, having a delta angle of 07°-44'-05", a radius of 260.00 feet, an arc length of 35.10 feet and a chord bearing North 79°-29'-09" East, a distance of 35.07 feet to a point;

With a curve to the left, having a delta angle of 70°-58'-30", a radius of 25.00 feet, an arc length of 30.97 feet and a chord bearing North 40°-07'-51" East, a distance of 29.03 feet to a point of tangency;

North 04°-38'-36" East, a distance of 61.50 feet to a point; and

South 85°-21'-24" East, a distance of 29.00 feet to the **POINT OF BEGINNING**.

Containing 0.112 acre, more or less.

The bearings in the above description are based on the grid bearing of North 00°-29'-59" East, for the easterly right-of-way of Kristina Drive as determined by a GPS network of field observations performed in January, 2022 and are based upon the Ohio State Plane Coordinate System, North Zone, NAD83 (2011).

All rebar set are 5/8 inch in diameter and 30 inches in length, with a yellow cap stamped "DLZ OHIO INC."

I certify that this description is based upon a survey conducted under my direct supervision in January, 2022 and that it and the information contained herein are true and correct to the best of my knowledge.

DLZ Ohio, Inc.

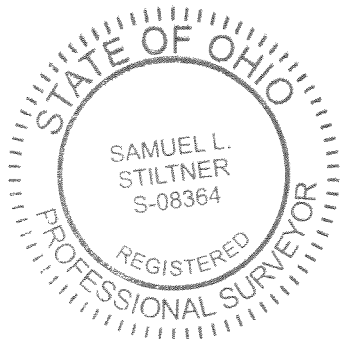

Samuel L. Stiltner 3/19/2022

Samuel L. Stiltner
Professional Surveyor No. 8364

2121-2184.00



4-28-2022



APPROVED



INNOVATIVE IDEAS
EXCEPTIONAL DESIGN
UNMATCHED CLIENT SERVICE

JLH REALTY LLC AND STONE KEP CORPORATION 4.895 ACRES

Situate in the State of Ohio, Logan County, Lake Township, City of Bellefontaine and lying Section 27, Town 4, Range 14, and being out of the 13.629 acres as conveyed to JLH Realty LLC and Stone Kep Corporation by deed of record in Official Record 1394, Page 4626 (all records referenced herein refer to the Logan County Records of Deeds) and being more particularly described as follows:

COMMENCE at a 5/8 inch iron rebar found at the southerly corner common to said 13.629 acre tract and Autumn Woods Condominiums as recorded in Plat Cabinet B, Slide 84B, and being on the north right-of-way line of Kristina Drive (60 feet wide);

THENCE, North 04°-38'-35" East, a distance of 400.85 feet, with the line common to said 13.629 acre tract and Autumn Woods Condominiums, to a 5/8 inch iron rebar set (I.D. cap stamped "DLZ OHIO INC") at the **TRUE POINT OF BEGINNING**;

THENCE, North 04°-38'-35" East, a distance of 270.73 feet, continuing with the line common to said 13.629 acre tract and Autumn Woods Condominiums, to a 3/4 inch iron pipe found (I.D. cap stamped "BDM #2") on the south line of that 10.881 acre tract as conveyed to Highpoint Holdings LLC by deed of record in Official Record 892, Page 804;

THENCE, South 82°-45'-30" East, a distance of 159.72 feet, with a line common to said 13.629 acre and 10.881 acre tracts, to a 5/8 inch iron rebar found (I.D. cap stamped "LEE PS6359");

THENCE, South 85°-21'-25" East, a distance of 329.89 feet, with a new division line through said 13.629 acre tract to a point, referenced by a 5/8 inch iron rebar set (I.D. cap stamped "DLZ OHIO INC") bearing North 04°-45'-37" East, a distance of 1.00 feet, on the westerly line of that 49.22 acre tract as conveyed to Michael D. Fitzpatrick et al by deed of record in Official Record 1090, Page 258, Parcel III, Tract 1, said westerly line also being an easterly Corporation line of the City of Bellefontaine;

THENCE, South 04°-45'-37" West, a distance of 638.93 feet, with lines common to said 13.629 acre and 49.22 acre tracts, the City of Bellefontaine Corporation Line, that 6.22 acre tract as conveyed to Michael D. Fitzpatrick et al, by deed of record in Official Record 1090, Page 258, Parcel III, Tract 2 and that 38.01 acre tract as conveyed to Larry L. Park, Trustee of the Larry L. Park Trust dated March 3, 2000 by deed of record in Official Record 1164, Page 465, Parcel 1, to a 5/8 inch iron rebar found (I.D. cap stamped "LEE PS6359") at a corner

INDEXED ON MAP
499

117 N Madriver St, Bellefontaine, OH 43311 | OFFICE 937.593.7335 | ONLINE WWW.DLZ.COM



INNOVATIVE IDEAS
EXCEPTIONAL DESIGN
UNMATCHED CLIENT SERVICE

common to said 13.629 acre tract and that 10.002 acre tract as conveyed to CDT-Lockwood Deercreek JV, LLC, by deed of record in Official Record 1213, Page 163, Parcel I;

THENCE, with the common line to said 13.629 acre and 10.002 acre tracts the following two (2) courses:

North 84°-25'-51" West, a distance of 231.86 feet to a point, passing a 5/8 inch iron rebar found (I.D. cap stamped "LEE PS7437") at 231.66; and

With a curve to the right, non-tangent to the previous course, having a delta angle of 33°-20'-21", a radius of 310.00 feet, an arc length of 180.38 feet, a chord bearing South 66°-39'-07" West, a distance of 177.85 feet to a 5/8 inch iron rebar set (I.D. cap stamped "DLZ OHIO INC");

THENCE, with new division lines through said 13.629 acre tract, the following six (6) courses:

THENCE, North 06°-40'-42" West, a distance of 70.00 feet, to a 5/8 inch iron rebar set (I.D. cap stamped "DLZ OHIO INC");

North 75°-55'-06" East, a distance of 57.69 feet to a 5/8 inch iron rebar set (I.D. cap stamped "DLZ OHIO INC");

North 04°-38'-36" East, a distance of 61.50 feet to a 5/8 inch iron rebar set (I.D. cap stamped "DLZ OHIO INC");

South 85°-21'-24" East, a distance of 178.17 feet to a 5/8 inch iron rebar set (I.D. cap stamped "DLZ OHIO INC");

North 04°-38'-35" East, a distance of 306.50 feet to a 5/8 inch iron rebar set (I.D. cap stamped "DLZ OHIO INC"); and

North 85°-21'-24" West, a distance of 318.33 feet to the **POINT OF BEGINNING**.

Containing 4.895 acres, more or less.

The bearings in the above description are based on the grid bearing of North 00°-29'-59" East, for the easterly right-of-way of Kristina Drive as determined by a GPS network of field observations performed in January, 2022 and are based upon the Ohio State Plane Coordinate System, North Zone, NAD83 (2011).

All rebar set are 5/8 inch in diameter and 30 inches in length, with a yellow cap stamped "DLZ OHIO INC."





INNOVATIVE IDEAS
EXCEPTIONAL DESIGN
UNMATCHED CLIENT SERVICE

I certify that this description is based upon a survey conducted under my direct supervision in January, 2022 and that it and the information contained herein are true and correct to the best of my knowledge.

DLZ Ohio, Inc.



Samuel L. Stiltner 4/28/2022

Samuel L. Stiltner
Professional Surveyor No. 8364

2121-2184.00



4-28-2022



APPROVED



INNOVATIVE IDEAS
EXCEPTIONAL DESIGN
UNMATCHED CLIENT SERVICE

JLH REALTY LLC AND STONE KEP CORPORATION 5.950 ACRES

Situate in the State of Ohio, Logan County, Lake Township, City of Bellefontaine and lying Section 27, Town 4, Range 14, and being out of the 13.629 acres as conveyed to JLH Realty LLC and Stone Kep Corporation by deed of record in Official Record 1394, Page 4626 (all records referenced herein refer to the Logan County Records of Deeds) and being more particularly described as follows:

BEGINNING at a 5/8 inch iron rebar found in the northerly line to said 13.629 acre tract and at the southwest corner of Lot 4682 of Jado Ville as recorded in Plat Cabinet A, Slides 713A, 713B and 715A, as conveyed to Brian K. Bowshier by deed of record in Official Record 1176, Page 769, and being on the easterly right-of-way line of Kelly Court (60 feet wide);

THENCE, South 83°-17'-32" East, a distance of 279.31 feet, with the line common to said 13.629 acre tract and Lot 4682, to a 5/8 inch iron rebar found on the westerly line of that original 65.82 acre tract as conveyed to Larry L. Park, Trustee of the Larry L. Park Trust dated March 3, 2000, by deed of record in Official Record 1164, Page 465, Parcel 2, Tract 2 and on an easterly Corporation line of the City of Bellefontaine;

THENCE, South 04°-45'-37" West, a distance of 760.90 feet, with a line common to said 13.629 acre and original 65.82 acre tracts, the City of Bellefontaine Corporation Line and that 49.22 acre tract as conveyed to Michael D. Fitzpatrick et al by deed of record in Official Record 1090, Page 258, Parcel III, Tract 1, passing a 5/8 inch iron rebar set (I.D. cap stamped "DLZ OHIO INC.") at a distance of 759.90 feet, to a point;

THENCE, N 85°-21'-25" West, a distance of 329.89 feet, with a new division line through said 13.629 acre tract, to a 5/8 inch iron rebar found (I.D. cap stamped "LEE PS6359") at a corner common to said 13.629 acre tract and that 10.881 acre tract as conveyed to Highpoint Holdings LLC by deed of record in Official Record 892, Page 804;

THENCE, North 01°-45'-08" East, a distance of 711.38 feet, with a line common to said 13.629 acre and 10.881 acre tracts, to a 3/4 inch iron pipe found (I.D. cap stamped "BDM #2");

THENCE, with lines common to proposed Kelly Court extension, the following two (2) courses:

With a curve to the left, having a delta angle of 212°-02'-58", a radius of 50.00 feet, an arc length of 185.04 feet, a chord bearing North 75°-53'-20" East, a





INNOVATIVE IDEAS
EXCEPTIONAL DESIGN
UNMATCHED CLIENT SERVICE

distance of 96.11 feet to a 5/8 inch iron rebar set (I.D. cap stamped "DLZ OHIO INC."); and

With a curve to the right, having a delta angle of 59°-22'-37", a radius of 30.00 feet, an arc length of 31.09 feet, a chord bearing North 00°-47'-26" West, a distance of 29.72 feet to the **POINT OF BEGINNING**.

Containing 5.950 acres, more or less.

The bearings in the above description are based on the grid bearing of North 00°-29'-59" East, for the easterly right-of-way of Kristina Drive as determined by a GPS network of field observations performed in January, 2022 and are based upon the Ohio State Plane Coordinate System, North Zone, NAD83 (2011).

All rebar set are 5/8 inch in diameter and 30 inches in length, with a yellow cap stamped "DLZ OHIO INC."

I certify that this description is based upon a survey conducted under my direct supervision in January, 2022 and that it and the information contained herein are true and correct to the best of my knowledge.

DLZ Ohio, Inc.



Samuel L. Stiltner 4/25/2022

Samuel L. Stiltner
Professional Surveyor No. 8364

2121-2184.00



SURVEY OF THREE TRACTS
 SECTION 27, TOWN 4, RANGE 14
 CITY OF BELLEFONTAINE
 LAKE TOWNSHIP
 LOGAN COUNTY, OHIO

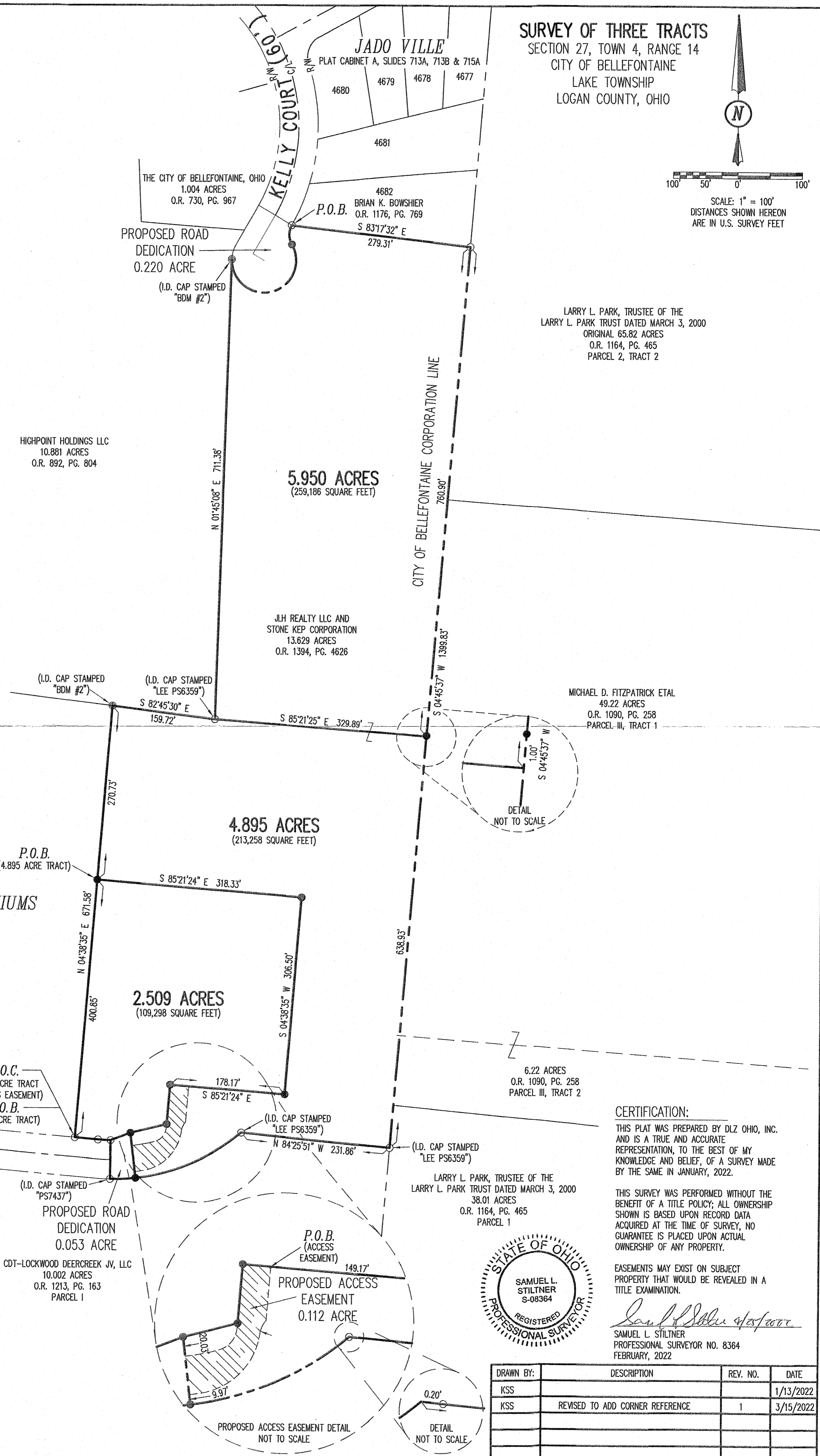
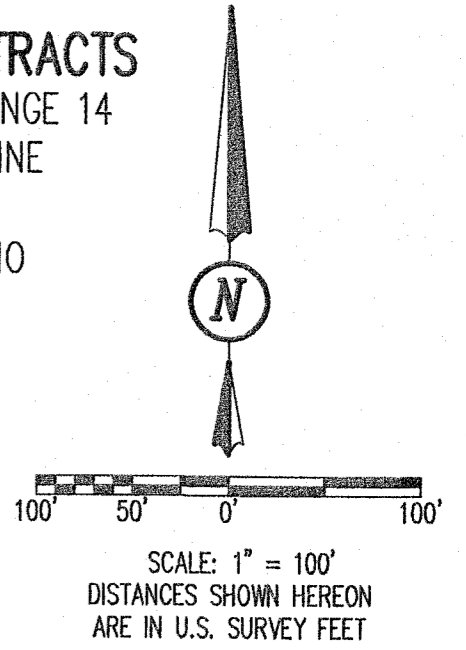

LEGEND:

- ⊙ 3/4 INCH IRON PIPE FOUND
- 5/8 INCH IRON REBAR FOUND
- 5/8 INCH BY 30 INCH IRON REBAR SET WITH YELLOW I.D. CAP STAMPED "DLZ OHIO INC."

P.O.C. = POINT OF COMMENCEMENT

P.O.C. = POINT OF COMMENCEMENT

P.O.B. = POINT OF BEGINNING

R/W = RIGHT-OF-WAY

C/L = CENTER-LINE

DEED & SURVEY REFERENCES:

DEED REFERENCES ARE SHOWN HEREON.

LOGAN COUNTY ENGINEER'S MAP ROOM FILES:
 4199A, 4199B, 4199C, 8014, 8943

OCCUPATION NOTE:

NO EVIDENCE OF OCCUPATION ALONG BOUNDARY LINES UNLESS OTHERWISE SHOWN

BASIS FOR BEARINGS:

BEARINGS AND DISTANCES, SHOWN HEREON, ARE DERIVED FROM GPS OBSERVATIONS BASED ON GRID NORTH, OHIO STATE PLANE COORDINATE SYSTEM, NORTH ZONE, NAD83 (2011, EPOCH 2010), WITH THE EASTERLY RIGHT-OF-WAY OF KRISTINA DRIVE, HAVING A BEARING OF N 00°29'59" E.

LARRY L. PARK, TRUSTEE OF THE
 LARRY L. PARK TRUST DATED MARCH 3, 2000
 ORIGINAL 65.82 ACRES
 O.R. 1164, PG. 465
 PARCEL 2, TRACT 2

MICHAEL D. FITZPATRICK ETAL
 49.22 ACRES
 O.R. 1090, PG. 258
 PARCEL III, TRACT 1

6.22 ACRES
 O.R. 1090, PG. 258
 PARCEL III, TRACT 2

LARRY L. PARK, TRUSTEE OF THE
 LARRY L. PARK TRUST DATED MARCH 3, 2000
 38.01 ACRES
 O.R. 1164, PG. 465
 PARCEL 1

CERTIFICATION:

THIS PLAT WAS PREPARED BY DLZ OHIO, INC. AND IS A TRUE AND ACCURATE REPRESENTATION, TO THE BEST OF MY KNOWLEDGE AND BELIEF, OF A SURVEY MADE BY THE SAME IN JANUARY, 2022.

THIS SURVEY WAS PERFORMED WITHOUT THE BENEFIT OF A TITLE POLICY; ALL OWNERSHIP SHOWN IS BASED UPON RECORD DATA ACQUIRED AT THE TIME OF SURVEY, NO GUARANTEE IS PLACED UPON ACTUAL OWNERSHIP OF ANY PROPERTY.

EASEMENTS MAY EXIST ON SUBJECT PROPERTY THAT WOULD BE REVEALED IN A TITLE EXAMINATION.

Samuel L. Stiltner
 SAMUEL L. STILTNER
 PROFESSIONAL SURVEYOR NO. 8364
 FEBRUARY, 2022

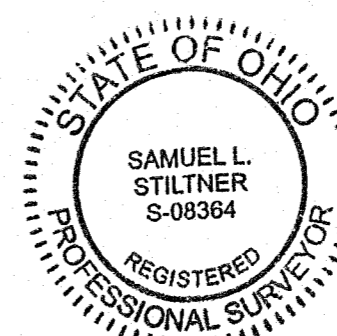

DRAWN BY:	DESCRIPTION	REV. NO.	DATE
KSS			1/13/2022
KSS	REVISED TO ADD CORNER REFERENCE	1	3/15/2022

COPYRIGHT 2022 BY:

 117 N. Madriver Street • Bellefontaine, OH 43311
 (937) 593-7335 • www.dlz.com
 Project #2121-2184.00REV1

3-10-2022



APPROVED



ARCHITECTURE • ENGINEERING • PLANNING
SURVEYING • CONSTRUCTION SERVICES

INNOVATIVE IDEAS
EXCEPTIONAL DESIGN
UNMATCHED CLIENT SERVICE

JLH REALTY LLC AND STONE KEP CORPORATION 0.220 ACRE

Situate in the State of Ohio, Logan County, Lake Township, City of Bellefontaine and lying Section 27, Town 4, Range 14, and being out of the 13.629 acres as conveyed to JLH Realty LLC and Stone Kep Corporation by deed of record in Official Record 1394, Page 4626 (all records referenced herein refer to the Logan County Records of Deeds) and being more particularly described as follows:

BEGINNING at a 5/8 inch iron rebar found in the northerly line of said 13.629 acre tract at the southwest corner of Lot 4682 of Jado Ville as recorded in Plat Cabinet A, Slides 713A, 713B and 715A, as conveyed to Brian K. Bowshier by deed of record in Official Record 1176, Page 769, and being on the easterly right-of-way line of Kelly Court (60 feet wide);

THENCE, with lines common to Kelly Court extended, the following five (5) courses:

With a curve to the left, having a delta angle of 59°-22'-37", a radius of 30.00 feet, an arc length of 31.09 feet, a chord bearing South 00°-47'-26" East, a distance of 29.72 feet to a 5/8 inch iron rebar set (I.D. cap stamped "DLZ OHIO INC.");

With a curve to the right, having a delta angle of 212°-02'-58", a radius of 50.00 feet, an arc length of 185.04 feet, a chord bearing South 75°-53'-20" West, a distance of 96.11 feet to a 3/4 inch iron pipe found (I.D. cap stamped "BDM #2) at a corner common to said 13.629 acre tract and that 10.881 acre tract as conveyed to Highpoint Holdings LLC by deed of record in Official Record 892, Page 804;

With a curve to the right, having a delta angle of 27°-49'-04", a radius of 50.00 feet, an arc length of 24.27 feet, a chord bearing North 15°-48'-57" East, a distance of 24.04 feet to a 3/4 inch iron pipe found at a corner common to said 13.629 acre and 10.881 acre tracts;

North 29°-44'-02" East, a distance of 68.85 feet, with a line common to said 13.629 acre and 10.881 acre tracts and that 1.004 acre tract as conveyed to The City of Bellefontaine, Ohio by deed of record in Official Record 730, Page 967, to a point on the westerly right-of-way line of said Kelly Court; and

South 60°-15'-58" East, a distance of 60.00 feet, with the terminus of Kelly Court, passing a 5/8 inch iron rebar found (I.D. cap stamped "PS7437") at a distance of 0.48 feet and a magnetic nail set at a distance of 30.00 feet, to the **POINT OF BEGINNING**.

Containing 0.220 acre, more or less.

The bearings in the above description are based on the grid bearing of North 00°-29'-59" East, for the easterly right-of-way of Kristina Drive as determined by a GPS network of field observations performed in January, 2022 and are based upon the Ohio State Plane Coordinate System, North Zone, NAD83 (2011).





INNOVATIVE IDEAS
EXCEPTIONAL DESIGN
UNMATCHED CLIENT SERVICE

All rebar set are 5/8 inch in diameter and 30 inches in length, with a yellow cap stamped "DLZ OHIO INC."

I certify that this description is based upon a survey conducted under my direct supervision in January, 2022 and that it and the information contained herein are true and correct to the best of my knowledge.

DLZ Ohio, Inc.



Samuel L. Stiltner 3/09/2022

Samuel L. Stiltner
Professional Surveyor No. 8364

2121-2184.00

