

**ANNEXATION DESCRIPTION**  
TERRITORY TO BE ANNEXED TO THE CITY OF BELLEFONTAINE

LYING IN VIRGINIA MILITARY SURVEY 4399 AND 4478, JEFFERSON TOWNSHIP, LOGAN COUNTY, OHIO.

BEING ALL OF THE DAVID A. THOMPSON AND JACQUELINE R. THOMPSON 5,000 ACRE TRACT AS DEEDED AND DESCRIBED IN OFFICIAL RECORD 533, PAGE 279 OF THE LOGAN COUNTY RECORDS OF DEEDS AND BEING MORE PARTICULARLY DESCRIBED AS FOLLOWS:

BEGINNING AT A POINT ON THE CENTER-LINE OF TOWNSHIP ROAD 179 AT THE SOUTHEAST CORNER OF WHISPERING PINES SUBDIVISION (PLAT CABINET A, SLIDE 681).

THENCE, WITH THE CENTER-LINE OF TOWNSHIP ROAD 179 AND THE EAST LINE OF VIRGINIA MILITARY SURVEYS 4399 AND 4478, S 5°-41'-10" W, A DISTANCE OF 300.00 FEET TO A POINT.

THENCE, WITH THE NORTH LINE OF THE WON BONG CHA 6,000 ACRE TRACT, (O.R. 252, PG. 973, TRACT 11), N 83°-46'-40" W, A DISTANCE OF 726.00 FEET TO A POINT.

THENCE, WITH THE EAST LINE OF WHISPERING PINES NO. 2, (PLAT CABINET A, SLIDE 697), N 5°-41'-10" E, A DISTANCE OF 300.00 FEET TO A POINT.

THENCE, WITH THE SOUTH LINE OF SAID WHISPERING PINES SUBDIVISION, S 83°-46'-40" E, A DISTANCE OF 726.00 FEET TO THE POINT OF BEGINNING.

CONTAINING 5,000 ACRES

THE BASIS FOR BEARINGS IS THE CENTER-LINE OF TOWNSHIP ROAD 179, BEING S 5°-41'-10" W, AND ALL OTHER BEARINGS ARE FROM DEED AND SURVEY RECORD. THIS DESCRIPTION IS FOR ANNEXATION PURPOSES ONLY AND IS NOT TO BE USED TO ESTABLISH PROPERTY LINES FOR CONSTRUCTION OR TRANSFER.

5.000 ACRES

DAVID A. THOMPSON AND  
JACQUELINE R. THOMPSON  
5,000 ACRES  
O.R. 533, PG. 279

CHARLES W. STANFORD AND  
CAROL L. STANFORD  
5.00 ACRES  
O.R. 490, PG. 429

CITY OF BELLEFONTAINE  
ANNEXATION MAP OF A  
5,000 ACRE TRACT  
VIRGINIA MILITARY SURVEY 4399 AND  
VIRGINIA MILITARY SURVEY 4478  
JEFFERSON TOWNSHIP  
LOGAN COUNTY, OHIO



LOGAN COUNTY COMMISSIONERS	<i>John Bayler</i>	4-23-02
	<i>James E. Gode</i>	4-23-02
	<i>John Yon</i>	4-23-02
LOGAN COUNTY ENGINEER	<i>Scott C. Coleman</i>	4-25-02
CHAIRMAN, TOWNSHIP TRUSTEES		
L.U.C. PLANNING DIRECTOR	<i>Jamark Lee</i>	11-19-02
MAYOR OF BELLEFONTAINE	<i>Robert C. Sutz</i>	11-09-02
PRESIDENT, CITY COUNCIL	<i>William R. Peterson</i>	10-17-02
CLERK, CITY COUNCIL	<i>Wibbi Graham</i>	10-22-02
PLAT PRE-APPROVED	<i>Jon C. Hines</i>	3-8-2002
PLAT CHECKED	<i>Jon C. Hines</i>	11-21-2002
CITY ORDINANCE NUMBER	02-86	10-8-02

TRANSFERRED THIS 25<sup>th</sup> DAY OF NOVEMBER, 20 02  
 AUDITOR, LOGAN COUNTY, OHIO *Michael E. Gode*  
 RECEIVED FOR RECORD AT 2:34 O'CLOCK P. M.  
 THIS 25<sup>th</sup> DAY OF November 20 02  
 RECORDED IN PLAT CABINET B, SLIDE 79B  
 RECORDER, LOGAN COUNTY, OHIO *Linda Harrow*

SURVEYOR'S AFFIDAVIT  
 THE ABOVE ANNEXATION MAP HAS BEEN PREPARED FROM RECORDS BY LEE SURVEYING & MAPPING COMPANY. THIS IS NOT A BOUNDARY SURVEY AS DEFINED IN 4753-57 OF THE OHIO ADMINISTRATIVE CODE.  
 BEARINGS ARE BASED UPON THE CENTER-LINE OF TOWNSHIP ROAD 179, BEING S 5°-41'-10" W, AND ALL OTHER BEARINGS ARE FROM ANGLES AND DISTANCES FROM DEED RECORD.  
 JEFFREY L. LEE  
 PROFESSIONAL SURVEYOR 6359  
 MARCH 3, 2002

Surveyor's Stamp # 2002012823

REC'D 4-23-04 SAM/OK

# Lee Surveying and Mapping Co., Inc.

Land Surveys • Topography • Subdivisions • Construction Layout

117 N. Madriver St.  
Bellefontaine OH 43311

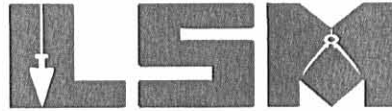

Phone: (937) 593-7335  
Fax: (937) 593-7444

## CHA "RETENTION POND TRACT" 0.702 ACRE

Lying in Virginia Military Survey 4478, City of Bellefontaine, Jefferson Township, Logan County, Ohio.

Being out of the Won Bong Cha and Hee Shoon Cha original 7.684 acre tract as deeded and described in Official Record 252, Page 973, Tract I, of the Logan County Records of Deeds and being more particularly described as follows:

Beginning at a 5/8 inch iron rod found at the northeast corner of Lot 5025 of Whispering Pines No. 4 (Plat Cabinet B, Slide 43B, 44 A&B).

THENCE, with the east lines of Lots 5025 and 5026 of Whispering Pines No. 4, S 6°-13'-03"W, a distance of 318.28 feet to a concrete monument set.

THENCE, S 83°-46'-40"E, a distance of 163.64 feet to a concrete monument set.

THENCE, with the west line of the Mary M. Mort 7.50 acre tract (O.R. 55, Pg. 608), S 6°-13'-20"W, a distance of 187.20 feet to a 5/8 inch iron rod set.

THENCE, with the north line of the Ross Investments Partnership 60.254 acre tract (Official Record 214, Page 278), N 83°-30'-52"W, a distance of 163.63 feet to a 5/8 inch iron rod set.

THENCE, with the east line of the aforesaid Lot 5026, N 6°-13'-03"E, a distance of 186.45 feet to the point of beginning.

Containing 0.702 acre.

The basis for bearings is the east lines of Lots 5026 and 5025 of Whispering Pines No. 4, being N 6°-13'-03"E, and all other bearings are from angles and distances measured in a field survey by Lee Surveying and Mapping Co., Inc. on October 7, 2003.



ORIGINAL STAMP IN GREEN

Description prepared by:

*Jeffrey I. Lee*  
Jeffrey I. Lee  
Professional Surveyor 6359  
April 21, 2004

L-3383

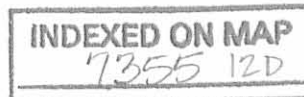

REC'D 4-23-04 SMJ OK

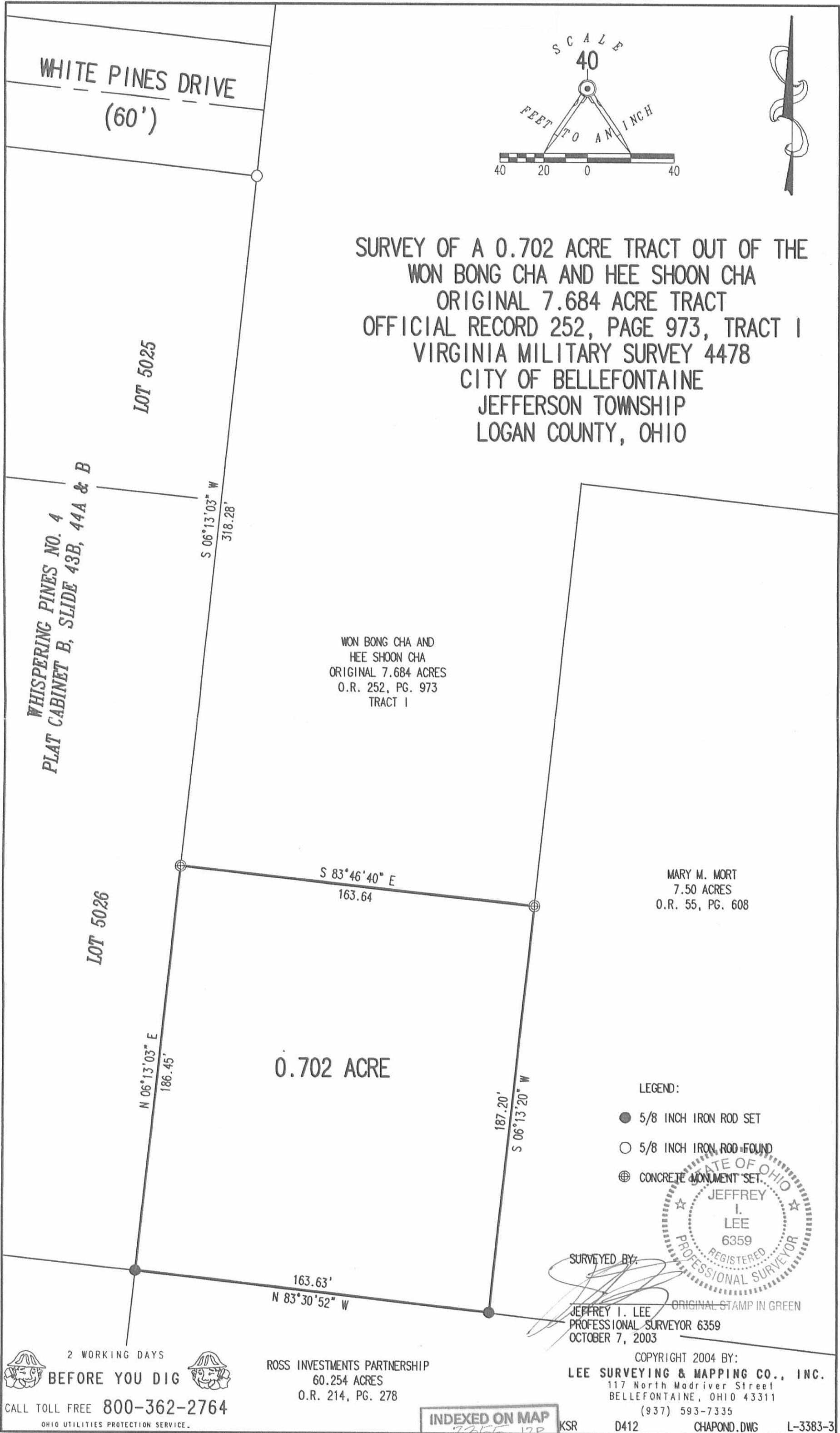

WHITE PINES DRIVE  
(60')

LOT 5025

WHISPERING PINES NO. 4  
PLAT CABINET B, SLIDE 43B, 44A & B

LOT 5026

SURVEY OF A 0.702 ACRE TRACT OUT OF THE  
 WON BONG CHA AND HEE SHOON CHA  
 ORIGINAL 7.684 ACRE TRACT  
 OFFICIAL RECORD 252, PAGE 973, TRACT I  
 VIRGINIA MILITARY SURVEY 4478  
 CITY OF BELLEFONTAINE  
 JEFFERSON TOWNSHIP  
 LOGAN COUNTY, OHIO

WON BONG CHA AND  
 HEE SHOON CHA  
 ORIGINAL 7.684 ACRES  
 O.R. 252, PG. 973  
 TRACT I

MARY M. MORT  
 7.50 ACRES  
 O.R. 55, PG. 608

0.702 ACRE

LEGEND:

- 5/8 INCH IRON ROD SET
- 5/8 INCH IRON ROD FOUND
- ⊕ CONCRETE MONUMENT SET



SURVEYED BY:

JEFFREY I. LEE  
 PROFESSIONAL SURVEYOR 6359  
 OCTOBER 7, 2003

ORIGINAL STAMP IN GREEN

2 WORKING DAYS  
**BEFORE YOU DIG**  
 CALL TOLL FREE 800-362-2764  
 OHIO UTILITIES PROTECTION SERVICE.

ROSS INVESTMENTS PARTNERSHIP  
 60.254 ACRES  
 O.R. 214, PG. 278

COPYRIGHT 2004 BY:  
**LEE SURVEYING & MAPPING CO., INC.**  
 117 North Madriver Street  
 BELLEFONTAINE, OHIO 43311  
 (937) 593-7335  
 CHAPOND.DWG L-3383-3

INDEXED ON MAP  
 7355 13P

KSR

D412

L-3383-3

REC'D 4-23-04 smy ac

# Lee Surveying and Mapping Co., Inc.

Land Surveys • Topography • Subdivisions • Construction Layout

117 N. Madriver St.  
Bellefontaine OH 43311

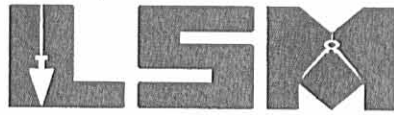

Phone: (937) 593-7335  
Fax: (937) 593-7444

## ROPP 0.207 ACRE

Lying in Virginia Military Survey 4478, City of Bellefontaine, Jefferson Township, Logan County, Ohio.

Being the remainder of the Donald W. Ropp and Carolyn L. Ropp original 126.776 acre tract as deeded and described in Volume 404, Page 255, Tract 2, of the Logan County Records of Deeds and being more particularly described as follows:

Beginning at a 5/8 inch iron rod found at the northeast corner of Lot 5025 of Whispering Pines No. 4 (Plat Cabinet B, Slide 43B, 44 A & B).

THENCE, with the east line of White Pines Drive and the east line of Lot 5000, N 6°-13'-03"E, a distance of 90.94 feet to a 5/8 inch iron rod set at the TRUE POINT OF BEGINNING.

THENCE, with the east line of Lot 5000, N 6°-13'-03"E, a distance of 30.00 feet to a 5/8 inch iron rod set.

THENCE, with the south line of the Won Bong Cha and Hee Shoon Cha 6.000 acre tract (O.R. 252, Pg. 973, Tract II), S 83°-46'-40"E, a distance of 300.05 feet to a 5/8 inch iron rod set.

THENCE, with the lines of the Wan Bong Cha and Hee Shoon Cha 7.684 acre tract (O.R. 252, Pg. 973, Tract I) the following two courses:

S 6°-13'-20"W, a distance of 30.18 feet to a 5/8 inch iron rod set.

N 83°-44'-35"W, a distance of 300.05 feet to the point of beginning.

Containing 0.207 acre.

The basis for bearings is the east line of Lot 5000, being N 6°-13'-03"E, and all other bearings are from angles and distances measured in a field survey by Lee Surveying and Mapping Co., Inc. on October 7, 2003

Description prepared by:



ORIGINAL STAMP IN GREEN

*[Signature]*  
Jeffrey I. Lee  
Professional Surveyor 6359  
April 21, 2004

L-3383

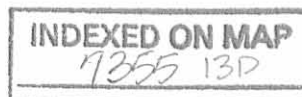

REC'D 4-23-04 8:11 AM

LOT 4999

LOT 5000

WHISPERING PINES NO. 4  
SLIDE 43B, 44 A&B  
CABINET B

WHITE PINES DR.  
(60 FEET WIDE)

LOT 5024

LOT 5025

WON BONG CHA AND  
HEE SHOON CHA  
6.000 ACRES  
O.R. 252, PG. 973  
TRACT II

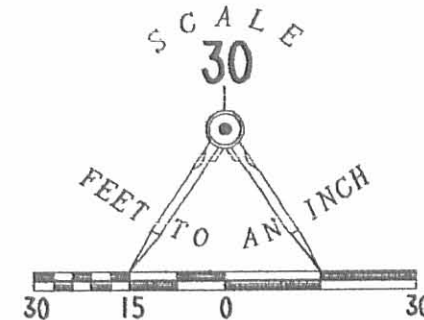

N 06° 13' 03" E  
30.00'

S 83° 46' 40" E  
300.05'

0.207 ACRE

300.05'  
N 83° 44' 35" W

30.18'  
S 06° 13' 20" W

WON BONG CHA AND  
HEE SHOON CHA  
7.684 ACRES  
O.R. 252, PG. 973  
TRACT I

SURVEY OF THE  
REMAINDER OF THE  
DONALD W. ROPP AND  
CAROLYN L. ROPP  
ORIGINAL 126.776 ACRE TRACT  
VOLUME 404, PAGE 255, TRACT 2  
VIRGINIA MILITARY SURVEY 4478  
CITY OF BELLEFONTAINE  
JEFFERSON TOWNSHIP  
LOGAN COUNTY, OHIO

SURVEYED BY:

*Jeffrey I. Lee*  
JEFFREY I. LEE  
PROFESSIONAL SURVEYOR 6359  
OCTOBER 7, 2003



ORIGINAL STAMP IN GREEN

COPYRIGHT 2003 BY:  
LEE SURVEYING & MAPPING CO., INC.  
117 North Madriver Street  
BELLEFONTAINE, OHIO 43311  
(937) 593-7335  
KSR D412 WONBONG4 L-3383-3

2 WORKING DAYS  
BEFORE YOU DIG  
CALL TOLL FREE 800-362-2764  
OHIO UTILITIES PROTECTION SERVICE.

INDEXED ON MAP  
7355 13P

# Lee Surveying and Mapping Co., Inc.

Land Surveys • Topography • Subdivisions • Construction Layout

117 N. Madriver St.  
Bellefontaine OH 43311

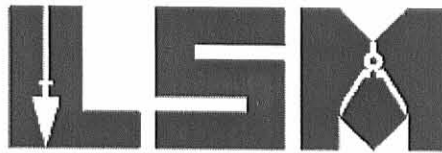

Phone: (937) 593-7335  
Fax: (937) 593-7444  
surveys@lsminc.us

## CHA 0.365 ACRE

Lying in Virginia Military Survey 4478, City of Bellefontaine, Jefferson Township, Logan County, Ohio.

Being out of the Won Bong Cha and Hee Shoon Cha original 7.684 acre tract as deeded and described in Official Record 252, Page 973, Tract I of the Logan County Records of Deeds and being more particularly described as follows:

Commencing on a railroad spike found on the intersection of the center-lines of Township Road 179 and White Pines Drive on an easterly line of the Bellefontaine Corporation Line.

THENCE, with the center-line of Township Road 179 (60 feet wide) and the Bellefontaine Corporation Line, S 06°-13'-20"W, a distance of 171.69 feet to a railroad spike found.

THENCE, with the Bellefontaine Corporation Line and the north line of the Lori D. Edwards 3.207 acre tract (O.R. 177, Pg. 820), N 82°-59'-44"W, a distance of 30.00 feet to a 5/8 inch iron rod found at the TRUE POINT OF BEGINNING.

THENCE, with the Bellefontaine Corporation Line and the north line of the said 3.207 acre tract, N 82°-59'-44"W, a distance of 114.00 feet to a 5/8 inch iron rod set.

THENCE, N 06°-13'-04"E, a distance of 139.72 feet to a 5/8 inch iron rod set on the south right-of-way of White Pines Drive.

THENCE, with the south right-of-way of White Pines Drive (60 feet wide), the following two courses:

S 83°-46'-40"E, a distance of 89.00 feet to a 5/8 inch iron rod set.

With a curve to the right, having a central angle of 90°-00'-00", a radius of 25.00 feet, an arc length of 39.27 feet, a chord bearing S 38°-46'-40"E, a distance of 35.36 feet to a 5/8 inch iron rod set on the west right-of-way of Township Road 179.

THENCE, with the west right-of-way of Township Road 179, S 06°-13'-20"W, a distance of 116.28 feet to the point of beginning.

Containing 0.365 acre.

Property is subject to any and all previous easements and rights-of-way of record.

The basis for bearings is the center-line of Township Road 179, being S 06°-13'-20"W, and all other bearings are from angles and distances measured in a field survey by Lee Surveying and Mapping Co., Inc. on July 31, 2012.

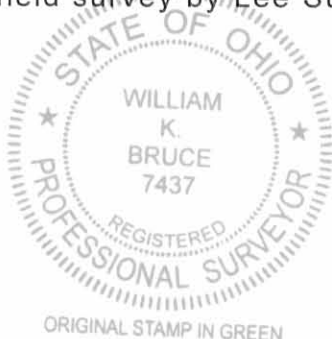

Description prepared by:

*William K. Bruce*

William K. Bruce  
Professional Surveyor 7437  
July 31, 2012

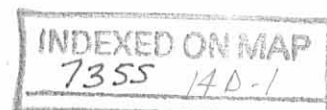

33830712

REID 8-17-12 SMY OK

# Lee Surveying and Mapping Co., Inc.

Land Surveys • Topography • Subdivisions • Construction Layout

117 N. Madriver St.  
Bellefontaine OH 43311



Phone: (937) 593-7335  
Fax: (937) 593-7444  
surveys@lsmcinc.us

## CHA 15.00 FEET WIDE DRAINAGE EASEMENT

Lying in Virginia Military Survey 4478, City of Bellefontaine, Jefferson Township, Logan County, Ohio.

Being a 15.00 feet wide drainage easement over a portion of the Won Bong Cha and Hee Shoon Cha original 7.684 acre tract as deeded and described in Official Record 252, Page 973, Tract I of the Logan County Records of Deeds and being more particularly described as follows:

Commencing on a railroad spike found on the intersection of the center-lines of Township Road 179 and White Pines Drive on an easterly line of the Bellefontaine Corporation Line.

THENCE, with the center-line of Township Road 179 (60 feet wide) and the Bellefontaine Corporation Line, S 06°-13'-20"W, a distance of 171.69 feet to a railroad spike found.

THENCE, with the Bellefontaine Corporation Line and the north line of the Lori D. Edwards 3.207 acre tract (O.R. 177, Pg. 820), N 82°-59'-44"W, a distance of 30.00 feet to a 5/8 inch iron rod found.

THENCE, with the Bellefontaine Corporation Line and the north line of the said 3.207 acre tract, N 82°-59'-44"W, a distance of 114.00 feet to a 5/8 inch iron rod set.

THENCE, N 06°-13'-04"E, a distance of 139.72 feet to a 5/8 inch iron rod set on the south right-of-way of White Pines Drive.

THENCE, with the south right-of-way of White Pines Drive (60 feet wide), S 83°-46'-40"E, a distance of 24.67 feet to a point at the TRUE POINT OF BEGINNING.

THENCE, with the center-line of the aforesaid 15.00 feet wide drainage easement, the following two courses:

S 09°-18'-51"W, a distance of 17.67 feet to a point.

S 03°-55'-43"E, a distance of 87.49 feet to a point at the terminus of this easement.

The sidelines of said easement to be shortened or prolonged to meet angle point intersections.

Property is subject to any and all previous easements and rights-of-way of record.

The basis for bearings is the center-line of Township Road 179, being S 06°-13'-20"W, and all other bearings are from angles and distances measured in a field survey by Lee Surveying and Mapping Co., Inc. on July 31, 2012.



ORIGINAL STAMP IN GREEN

Description prepared by:

William K. Bruce  
Professional Surveyor 7437  
August 14, 2012

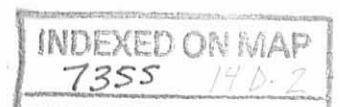

33830712REV

REC'D 8-17-12 SWY OR

CURVE	DELTA ANGLE	RADIUS	ARC LENGTH	CHORD BEARING	CHORD LENGTH
C1	90°00'00"	25.00'	39.27'	S 38°46'40" E	35.36'

LINE	BEARING	DISTANCE
L1	S 09°18'51" W	17.67'
L2	S 03°55'43" E	87.49'

- LEGEND:
- ⊗ RAILROAD SPIKE FOUND
  - 5/8 INCH IRON ROD FOUND
  - 5/8 INCH IRON ROD SET WITH PLASTIC I.D. CAP STAMPED "LSM 7437"
  - B.S. = BUILDING SETBACK

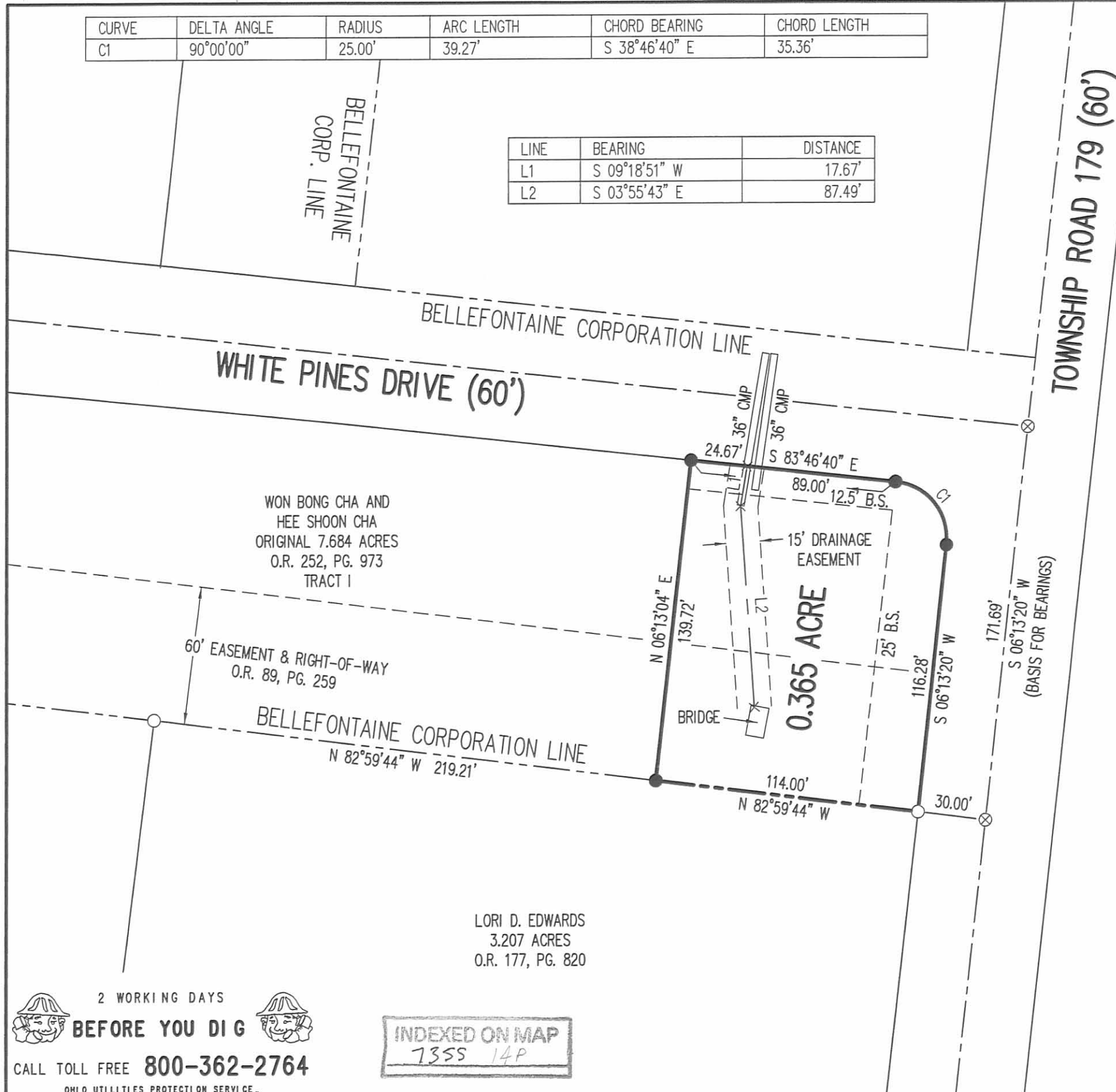
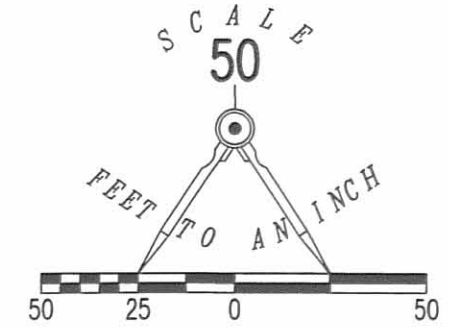

SURVEY OF 0.365 ACRE OUT OF THE  
 WON BONG CHA AND  
 HEE SHOON CHA  
 ORIGINAL 7.684 ACRE TRACT  
 OFFICIAL RECORD 252, PAGE 973  
 TRACT I  
 VIRGINIA MILITARY SURVEY 4478  
 CITY OF BELLEFONTAINE  
 JEFFERSON TOWNSHIP  
 LOGAN COUNTY, OHIO

SURVEYED BY:

*William K. Bruce*

WILLIAM K. BRUCE  
 PROFESSIONAL SURVEYOR 7437  
 JULY 31, 2012  
 REVISED AUGUST 14, 2012 (TO CHANGE DRAINAGE  
 EASEMENT TO 15 FEET WIDE AS REQUESTED BY THE  
 CITY OF BELLEFONTAINE ENGINEER)



COPYRIGHT 2012 BY:  
**LEE SURVEYING & MAPPING CO., INC.**  
 117 North Madriver Street  
 BELLEFONTAINE, OHIO 43311  
 (937) 593-7335  
 WWW.LSMINC.US  
 surveys@lsminc.us  
 KSS D0712 33830712REV L-3383-3

LORI D. EDWARDS  
 3.207 ACRES  
 O.R. 177, PG. 820

2 WORKING DAYS  
**BEFORE YOU DIG**  
 CALL TOLL FREE **800-362-2764**  
 OHIO UTILITIES PROTECTION SERVICE

INDEXED ON MAP  
 7355 14P



6-18-14

# Lee Surveying and Mapping Co., Inc.

**APPROVED** Land Surveys • Topography • Subdivisions • Construction Layout

117 N. Madriver St.  
Bellefontaine OH 43311

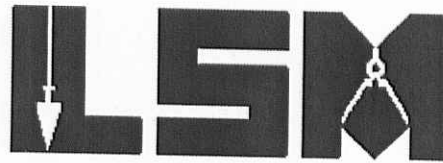

Phone: (937) 593-7335  
Fax: (937) 593-7444  
surveys@lsminc.us

## CHA 0.382 ACRE

Lying in Virginia Military Survey 4478, City of Bellefontaine, Jefferson Township, Logan County, Ohio.

Being out of the Won Bong Cha and Hee Shoon Cha remainder of the original 7.684 acre tract as deeded and described in Official Record 252, Page 973, Tract I of the Logan County Records of Deeds and being more particularly described as follows:

Commencing on a railroad spike found on the intersection of the center-lines of Township Road 179 and White Pines Drive.

THENCE, with the center-line of Township Road 179 (60 feet wide), S 06°-13'-20"W, a distance of 171.69 feet to a railroad spike found on a south Bellefontaine Corporation Line.

THENCE, with a south Bellefontaine Corporation Line and the north line of the Lori D. Edwards 3.207 acre tract (O.R. 177, Pg. 820), N 82°-59'-44"W, a distance of 363.21 feet to a 5/8 inch iron rod found, passing a 5/8 inch iron rod found at 144.00 feet and a railroad spike set at 254.38 feet.

THENCE, with a south Bellefontaine Corporation Line and the north line of the Mary M. Mort original 7.50 acre tract (O.R. 89, Pg. 259), N 83°-00'-11"W, a distance of 367.57 feet to a 5/8 inch iron rod set at the TRUE POINT OF BEGINNING, passing a 6 inch apple tree at 4.01 feet, a railroad spike set at 120.61 feet and a 5/8 inch iron rod set at 241.66 feet.

THENCE, with a south Bellefontaine Corporation Line and the north line of the said original 7.50 acre tract, N 83°-00'-11"W, a distance of 131.64 feet to a 5/8 inch iron rod found.

THENCE, with the east line of Lot 4919 of Belle Pines Subdivision (Plat Cabinet B, Slides 93A & 94B), N 06°-13'-20"E, a distance of 124.77 feet to a 5/8 inch iron rod found on the south right-of-way of White Pines Drive (60 feet wide).

THENCE, with the south right-of-way of White Pines Drive (Plat Cabinet B, Slides 93A & 93B), S 84°-18'-19"E, a distance of 131.64 feet to a 5/8 inch iron rod set.

# Lee Surveying and Mapping Co., Inc.

Land Surveys • Topography • Subdivisions • Construction Layout

117 N. Madriver St.  
Bellefontaine OH 43311

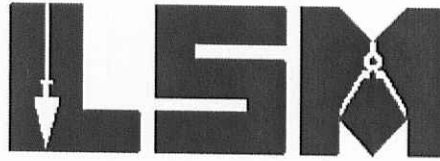

Phone: (937) 593-7335  
Fax: (937) 593-7444  
surveys@lsminc.us

THENCE, S 06°-13'-20"W, a distance of 127.76 feet to the point of beginning.

Containing 0.382 acre.

Property is subject to any and all previous easements and rights-of-way of record.

The basis for bearings is the center-line of Township Road 179, being S 06°-13'-20"W, and all other bearings are from angles and distances measured in a field survey by Lee Surveying and Mapping Co., Inc. on June 3, 2014



ORIGINAL STAMP IN GREEN

Description prepared by:

A handwritten signature in black ink that reads 'William K. Bruce'.

William K. Bruce  
Professional Surveyor 7437  
June 4, 2014

33830414

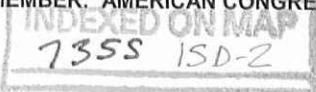

6-18-14

# Lee Surveying and Mapping Co., Inc.



Land Surveys • Topography • Subdivisions • Construction Layout

117 N. Madriver St.  
Bellefontaine OH 43311

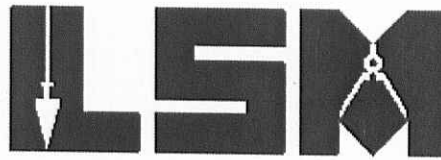

Phone: (937) 593-7335  
Fax: (937) 593-7444  
surveys@lsminc.us

## CHA 0.352 ACRE

Lying in Virginia Military Survey 4478, City of Bellefontaine, Jefferson Township, Logan County, Ohio.

Being out of the Won Bong Cha and Hee Shoon Cha remainder of the original 7.684 acre tract as deeded and described in Official Record 252, Page 973, Tract I of the Logan County Records of Deeds and being more particularly described as follows:

Commencing on a railroad spike found on the intersection of the center-lines of Township Road 179 and White Pines Drive.

THENCE, with the center-line of Township Road 179 (60 feet wide), S 06°-13'-20"W, a distance of 171.69 feet to a railroad spike found on a south Bellefontaine Corporation Line.

THENCE, with a south Bellefontaine Corporation Line and the north line of the Lori D. Edwards 3.207 acre tract (O.R. 177, Pg. 820), N 82°-59'-44"W, a distance of 144.00 feet to a 5/8 inch iron rod found at the TRUE POINT OF BEGINNING.

THENCE, with a south Bellefontaine Corporation Line and the north line of the said 3.207 acre tract, N 82°-59'-44"W, a distance of 110.38 feet to a railroad spike set.

THENCE, N 06°-13'-03"E, a distance of 138.22 feet to a 5/8 inch iron rod set on the south right-of-way of White Pines Drive (60 feet wide).

THENCE, with the south right-of-way of White Pines Drive (Plat Cabinet B, Slides 93A & 93B), S 83°-46'-40"E, a distance of 110.37 feet to a 5/8 inch iron rod found.

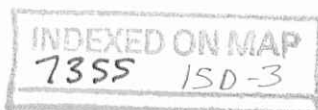

# Lee Surveying and Mapping Co., Inc.

Land Surveys • Topography • Subdivisions • Construction Layout

117 N. Madriver St.  
Bellefontaine OH 43311



Phone: (937) 593-7335  
Fax: (937) 593-7444  
surveys@lsminc.us

THENCE, with the Hee Shoon Cha and Won Bong Cha 0.365 acre tract (O.R. 1131, Pg. 490), S 06°-13'-03"W, a distance of 139.72 feet to the point of beginning.

Containing 0.352 acre.

Property is subject to any and all previous easements and rights-of-way of record.

The basis for bearings is the center-line of Township Road 179, being S 06°-13'-20"W, and all other bearings are from angles and distances measured in a field survey by Lee Surveying and Mapping Co., Inc. on June 3, 2014



ORIGINAL STAMP IN GREEN

Description prepared by:

A handwritten signature in black ink that reads 'William K. Bruce'.

William K. Bruce  
Professional Surveyor 7437  
June 4, 2014

33830414

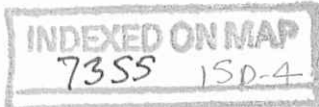

6-18-14

# Lee Surveying and Mapping Co., Inc.



Land Surveys • Topography • Subdivisions • Construction Layout

117 N. Madriver St.  
Bellefontaine OH 43311



Phone: (937) 593-7335  
Fax: (937) 593-7444  
surveys@lsminc.us

## CHA 0.356 ACRE

Lying in Virginia Military Survey 4478, City of Bellefontaine, Jefferson Township, Logan County, Ohio.

Being out of the Won Bong Cha and Hee Shoon Cha remainder of the original 7.684 acre tract as deeded and described in Official Record 252, Page 973, Tract I of the Logan County Records of Deeds and being more particularly described as follows:

Commencing on a railroad spike found on the intersection of the center-lines of Township Road 179 and White Pines Drive.

THENCE, with the center-line of Township Road 179 (60 feet wide), S 06°-13'-20"W, a distance of 171.69 feet to a railroad spike found on a south Bellefontaine Corporation Line.

THENCE, with a south Bellefontaine Corporation Line and the north line of the Lori D. Edwards 3.207 acre tract (O.R. 177, Pg. 820), N 82°-59'-44"W, a distance of 254.38 feet to a railroad spike set at the TRUE POINT OF BEGINNING, passing a 5/8 inch iron rod found at 144.00 feet.

THENCE, with a south Bellefontaine Corporation Line and the north line of the said 3.207 acre tract, N 82°-59'-44"W, a distance of 108.83 feet to a 5/8 inch iron rod found.

THENCE, with a south Bellefontaine Corporation Line and the north line of the Mary M. Mort original 7.50 acre tract (O.R. 55, Pg. 608), N 83°-00'-11"W, a distance of 4.01 feet to a 6 inch apple tree.

THENCE, N 06°-13'-03"E, a distance of 136.03 feet to a 5/8 inch iron rod set on the south right-of-way of White Pines Drive (60 feet wide), passing a 5/8 inch iron rod set at 1.00 feet.

THENCE, with the south right-of-way of White Pines Drive (Plat Cabinet B, Slides 93A & 93B), the following two courses:

S 84°-18'-19"E, a distance of 70.54 feet to a 5/8 inch iron rod found.

# Lee Surveying and Mapping Co., Inc.

Land Surveys • Topography • Subdivisions • Construction Layout

117 N. Madriver St.  
Bellefontaine OH 43311



Phone: (937) 593-7335  
Fax: (937) 593-7444  
surveys@lsminc.us

S 83°-46'-40"E, a distance of 42.30 feet to a 5/8 inch iron rod set.

THENCE, S 06°-13'-03"W, a distance of 138.22 feet to the point of beginning.

Containing 0.356 acre.

Property is subject to any and all previous easements and rights-of-way of record.

The basis for bearings is the center-line of Township Road 179, being S 06°-13'-20"W, and all other bearings are from angles and distances measured in a field survey by Lee Surveying and Mapping Co., Inc. on June 3, 2014

Description prepared by:



ORIGINAL STAMP IN GREEN

A handwritten signature in black ink that reads 'William K. Bruce'.

William K. Bruce  
Professional Surveyor 7437  
June 4, 2014

33830414

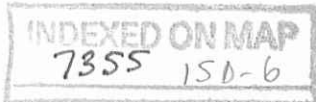

6-18-14

# Lee Surveying and Mapping Co., Inc.



Land Surveys • Topography • Subdivisions • Construction Layout

117 N. Madriver St.  
Bellefontaine OH 43311

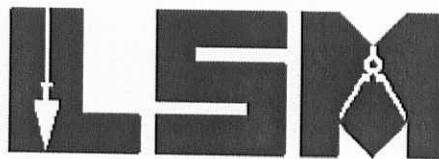

Phone: (937) 593-7335  
Fax: (937) 593-7444  
surveys@lsminc.us

## CHA 0.361 ACRE

Lying in Virginia Military Survey 4478, City of Bellefontaine, Jefferson Township, Logan County, Ohio.

Being out of the Won Bong Cha and Hee Shoon Cha remainder of the original 7.684 acre tract as deeded and described in Official Record 252, Page 973, Tract I of the Logan County Records of Deeds and being more particularly described as follows:

Commencing on a railroad spike found on the intersection of the center-lines of Township Road 179 and White Pines Drive.

THENCE, with the center-line of Township Road 179 (60 feet wide), S 06°-13'-20"W, a distance of 171.69 feet to a railroad spike found on a south Bellefontaine Corporation Line.

THENCE, with a south Bellefontaine Corporation Line and the north line of the Lori D. Edwards 3.207 acre tract (O.R. 177, Pg. 820), N 82°-59'-44"W, a distance of 363.21 feet to a 5/8 inch iron rod found, passing a 5/8 inch iron rod found at 144.00 feet and a railroad spike set at 254.38 feet.

THENCE, with a south Bellefontaine Corporation Line and the north line of the Mary M. Mort original 7.50 acre tract (O.R. 89, Pg. 259), N 83°-00'-11"W, a distance of 4.01 feet to a 6 inch apple tree at the TRUE POINT OF BEGINNING.

THENCE, with a south Bellefontaine Corporation Line and the north line of the said original 7.50 acre tract, N 83°-00'-11"W, a distance of 116.60 feet to a railroad spike set.

THENCE, N 06°-13'-20"E, a distance of 133.38 feet to a 5/8 inch iron rod set on the south right-of-way of White Pines Drive (60 feet wide).

THENCE, with the south right-of-way of White Pines Drive (Plat Cabinet B, Slides 93A & 93B), S 84°-18'-19"E, a distance of 116.58 feet to a 5/8 inch iron rod set.

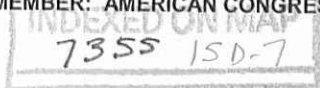

# Lee Surveying and Mapping Co., Inc.

Land Surveys • Topography • Subdivisions • Construction Layout

117 N. Madriver St.  
Bellefontaine OH 43311



Phone: (937) 593-7335  
Fax: (937) 593-7444  
surveys@lsminc.us

THENCE, S 06°-13'-03"W, a distance of 136.03 feet to the point of beginning, passing a 5/8 inch iron rod set at 135.24 feet.

Containing 0.361 acre.

Property is subject to any and all previous easements and rights-of-way of record.

The basis for bearings is the center-line of Township Road 179, being S 06°-13'-20"W, and all other bearings are from angles and distances measured in a field survey by Lee Surveying and Mapping Co., Inc. on June 3, 2014



ORIGINAL STAMP IN GREEN

Description prepared by:

A handwritten signature in black ink that reads 'William K. Bruce'.

William K. Bruce  
Professional Surveyor 7437  
June 4, 2014

33830414



6-18-14

# Lee Surveying and Mapping Co., Inc.



Land Surveys • Topography • Subdivisions • Construction Layout

117 N. Madriver St.  
Bellefontaine OH 43311



Phone: (937) 593-7335  
Fax: (937) 593-7444  
surveys@lsminc.us

## CHA 0.367 ACRE

Lying in Virginia Military Survey 4478, City of Bellefontaine, Jefferson Township, Logan County, Ohio.

Being out of the Won Bong Cha and Hee Shoon Cha remainder of the original 7.684 acre tract as deeded and described in Official Record 252, Page 973, Tract I of the Logan County Records of Deeds and being more particularly described as follows:

Commencing on a railroad spike found on the intersection of the center-lines of Township Road 179 and White Pines Drive.

THENCE, with the center-line of Township Road 179 (60 feet wide), S 06°-13'-20"W, a distance of 171.69 feet to a railroad spike found on a south Bellefontaine Corporation Line.

THENCE, with a south Bellefontaine Corporation Line and the north line of the Lori D. Edwards 3.207 acre tract (O.R. 177, Pg. 820), N 82°-59'-44"W, a distance of 363.21 feet to a 5/8 inch iron rod found, passing a 5/8 inch iron rod found at 144.00 feet and a railroad spike set at 254.38 feet.

THENCE, with a south Bellefontaine Corporation Line and the north line of the Mary M. Mort original 7.50 acre tract (O.R. 89, Pg. 259), N 83°-00'-11"W, a distance of 120.61 feet to a railroad spike set at the TRUE POINT OF BEGINNING, passing a 6 inch apple tree at 4.01 feet.

THENCE, with a south Bellefontaine Corporation Line and the north line of the said original 7.50 acre tract, N 83°-00'-11"W, a distance of 121.05 feet to a 5/8 inch iron rod set.

THENCE, N 06°-13'-20"E, a distance of 130.62 feet to a 5/8 inch iron rod set on the south right-of-way of White Pines Drive (60 feet wide).

THENCE, with the south right-of-way of White Pines Drive (Plat Cabinet B, Slides 93A & 93B), S 84°-18'-19"E, a distance of 121.04 feet to a 5/8 inch iron rod set.

7355 1SD-9

# Lee Surveying and Mapping Co., Inc.

Land Surveys • Topography • Subdivisions • Construction Layout

117 N. Madriver St.  
Bellefontaine OH 43311

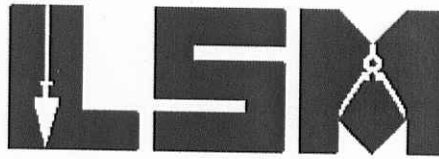

Phone: (937) 593-7335  
Fax: (937) 593-7444  
surveys@lsminc.us

THENCE, S 06°-13'-20"W, a distance of 133.38 feet to the point of beginning.

Containing 0.367 acre.

Property is subject to any and all previous easements and rights-of-way of record.

The basis for bearings is the center-line of Township Road 179, being S 06°-13'-20"W, and all other bearings are from angles and distances measured in a field survey by Lee Surveying and Mapping Co., Inc. on June 3, 2014



ORIGINAL STAMP IN GREEN

Description prepared by:

A handwritten signature in black ink that reads 'William K. Bruce'.

William K. Bruce  
Professional Surveyor 7437  
June 4, 2014

33830414

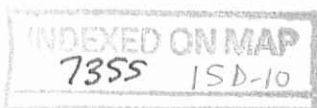

6-18-14

# Lee Surveying and Mapping Co., Inc.



Land Surveys • Topography • Subdivisions • Construction Layout

117 N. Madriver St.  
Bellefontaine OH 43311

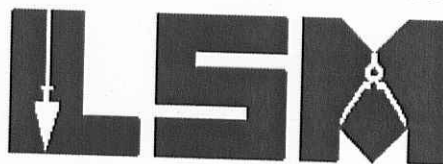

Phone: (937) 593-7335  
Fax: (937) 593-7444  
surveys@lsminc.us

## CHA 0.373 ACRE

Lying in Virginia Military Survey 4478, City of Bellefontaine, Jefferson Township, Logan County, Ohio.

Being out of the Won Bong Cha and Hee Shoon Cha remainder of the original 7.684 acre tract as deeded and described in Official Record 252, Page 973, Tract I of the Logan County Records of Deeds and being more particularly described as follows:

Commencing on a railroad spike found on the intersection of the center-lines of Township Road 179 and White Pines Drive.

THENCE, with the center-line of Township Road 179 (60 feet wide), S 06°-13'-20"W, a distance of 171.69 feet to a railroad spike found on a south Bellefontaine Corporation Line.

THENCE, with a south Bellefontaine Corporation Line and the north line of the Lori D. Edwards 3.207 acre tract (O.R. 177, Pg. 820), N 82°-59'-44"W, a distance of 363.21 feet to a 5/8 inch iron rod found, passing a 5/8 inch iron rod found at 144.00 feet and a railroad spike set at 254.38 feet.

THENCE, with a south Bellefontaine Corporation Line and the north line of the Mary M. Mort original 7.50 acre tract (O.R. 89, Pg. 259), N 83°-00'-11"W, a distance of 241.66 feet to a 5/8 inch iron rod set at the TRUE POINT OF BEGINNING, passing a 6 inch apple tree at 4.01 feet and a railroad spike set at 120.61 feet.

THENCE, with a south Bellefontaine Corporation Line and the north line of the said original 7.50 acre tract, N 83°-00'-11"W, a distance of 125.91 feet to a 5/8 inch iron rod set.

THENCE, N 06°-13'-20"E, a distance of 127.76 feet to a 5/8 inch iron rod set on the south right-of-way of White Pines Drive (60 feet wide).

THENCE, with the south right-of-way of White Pines Drive (Plat Cabinet B, Slides 93A & 93B), S 84°-18'-19"E, a distance of 125.90 feet to a 5/8 inch iron rod set.

7355 15D-11

# Lee Surveying and Mapping Co., Inc.

Land Surveys • Topography • Subdivisions • Construction Layout

117 N. Madriver St.  
Bellefontaine OH 43311



Phone: (937) 593-7335  
Fax: (937) 593-7444  
surveys@lsminc.us

THENCE, S 06°-13'-20"W, a distance of 130.62 feet to the point of beginning.

Containing 0.373 acre.

Property is subject to any and all previous easements and rights-of-way of record.

The basis for bearings is the center-line of Township Road 179, being S 06°-13'-20"W, and all other bearings are from angles and distances measured in a field survey by Lee Surveying and Mapping Co., Inc. on June 3, 2014



ORIGINAL STAMP IN GREEN

Description prepared by:

A handwritten signature in black ink that reads 'William K. Bruce'.

William K. Bruce  
Professional Surveyor 7437  
June 4, 2014

33830414

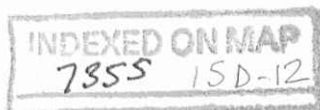

6-18-14

APPROVED

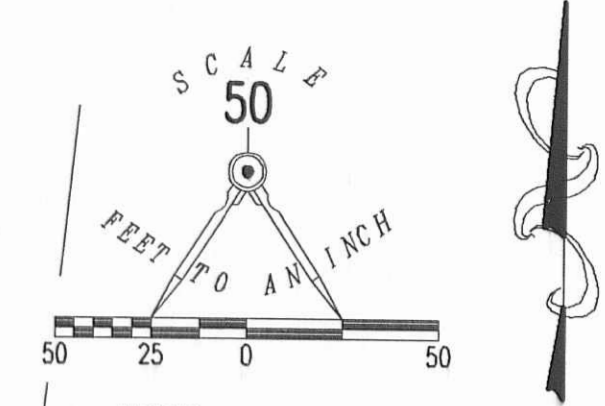
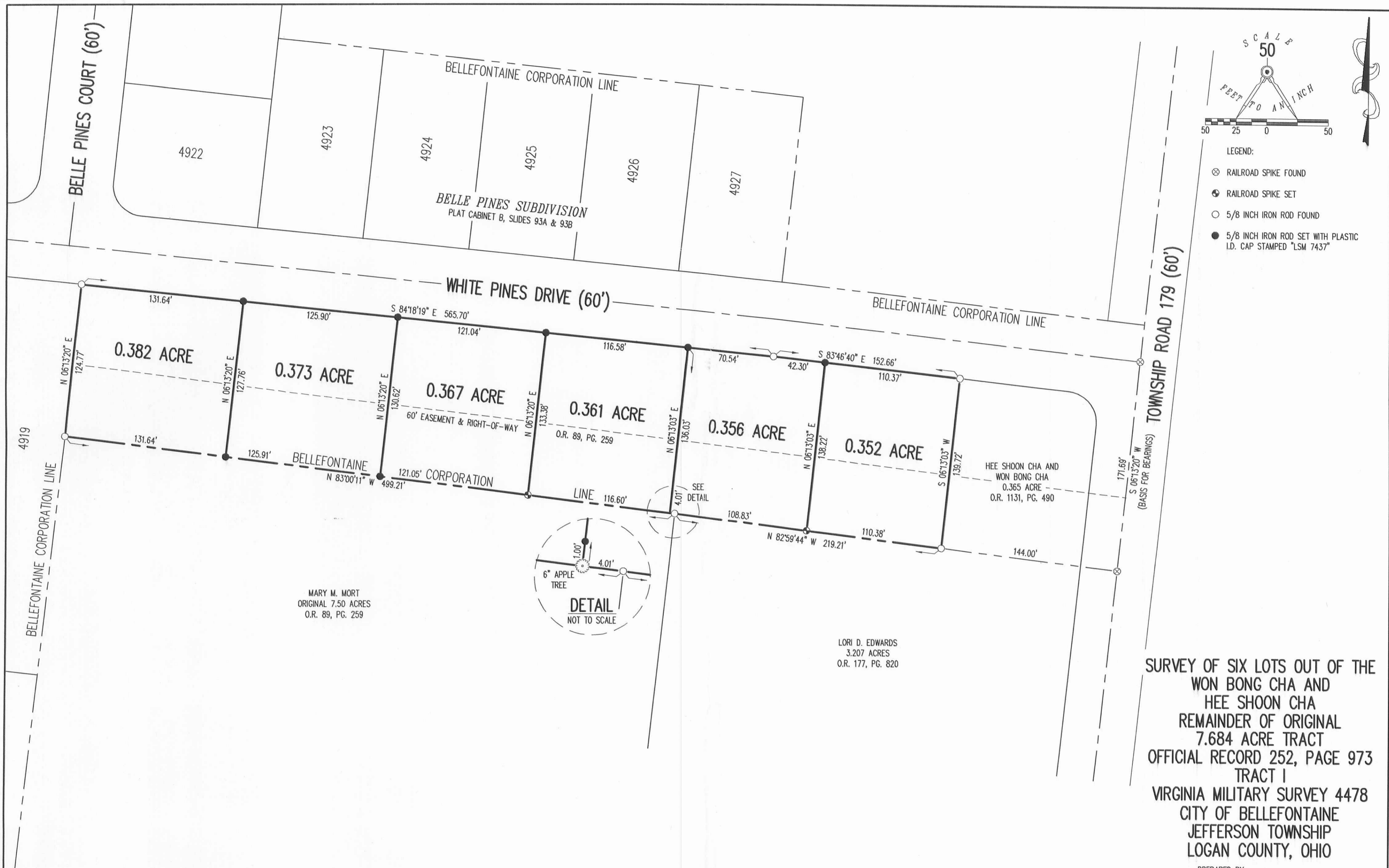

- LEGEND:
- ⊗ RAILROAD SPIKE FOUND
  - ⊕ RAILROAD SPIKE SET
  - 5/8 INCH IRON ROD FOUND
  - 5/8 INCH IRON ROD SET WITH PLASTIC I.D. CAP STAMPED "LSM 7437"

MARY M. MORT  
ORIGINAL 7.50 ACRES  
O.R. 89, PG. 259

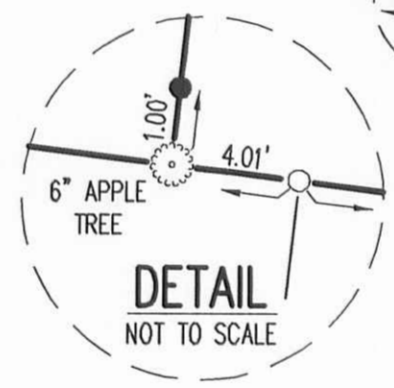

LORI D. EDWARDS  
3.207 ACRES  
O.R. 177, PG. 820

SURVEY OF SIX LOTS OUT OF THE  
WON BONG CHA AND  
HEE SHOON CHA  
REMAINDER OF ORIGINAL  
7.684 ACRE TRACT  
OFFICIAL RECORD 252, PAGE 973  
TRACT I  
VIRGINIA MILITARY SURVEY 4478  
CITY OF BELLEFONTAINE  
JEFFERSON TOWNSHIP  
LOGAN COUNTY, OHIO

PREPARED BY:

*William K. Bruce*  
WILLIAM K. BRUCE  
PROFESSIONAL SURVEYOR 7437  
JUNE 3, 2014



COPYRIGHT 2014 BY:  
LEE SURVEYING & MAPPING CO., INC.  
117 North Madriver Street  
BELLEFONTAINE, OHIO 43311  
(937) 593-7335  
WWW.LSMINC.US  
surveys@lsminc.us  
KSS D0414 33830414 L-3383-2

2 WORKING DAYS  
BEFORE YOU DIG  
CALL TOLL FREE 800-362-2764  
OHIO UTILITIES PROTECTION SERVICE

INDEXED ON MAP  
7355 ISP

10-2-2020

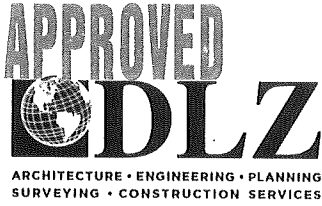

INNOVATIVE IDEAS  
EXCEPTIONAL DESIGN  
UNMATCHED CLIENT SERVICE

**WON BONG CHA  
TRACT A  
0.295 ACRE**

Lying in Virginia Military Survey 4478, City of Bellefontaine, Jefferson Township, Logan County, Ohio (all records referenced herein refer to the Logan County Records of Deeds).

Being out of the Won Bong Cha 2.203 acre tract as deeded and described in Official Record 1321, Page 195, Tract I, and being more particularly described as follows:

**BEGINNING** at a 5/8 inch iron rebar set at a common northerly corner to Lot 4919 of Belle Pines Subdivision(Plat Cabinet B, Slides 93A & 93B) and said 2.203 acre tract;

**THENCE, South 85°-28'-25" East**, along a common line to the northerly line of said 2.203 acre tract and the southerly right-of-way line of White Pines Drive (60 feet wide), a distance of **101.33 feet** to a 5/8 inch iron rebar set;

**THENCE, South 04°-31'-35" West**, with a new division line through said 2.203 acre tract, a distance of **127.10 feet** to a 5/8 inch iron rebar set on a common line to the northerly line of the William A. Siekierka 4.293 acre tract as deeded and described in Official Record 1322, Page 114, the southerly line of said 2.203 acre tract and the Bellefontaine Corporation line;

**THENCE, North 84°-10'-16" West**, along said common line, a distance of **102.51 feet** to a 5/8 inch iron rebar found(I.D. cap "LEE") on the easterly line of said Lot 4919;

**THENCE, North 05°-03'-14" East**, along a common line to the westerly line of said 2.203 acre tract and the easterly line of said Lot 4919, a distance of **124.77 feet** to the **POINT OF BEGINNING**.

Containing **0.295 acre**, more or less.

Iron rebar set, where indicated, are 30 inches in length, 5/8 inch in diameter with a plastic I.D. cap stamped "DLZ OHIO INC."

Property is subject to any and all previous easements and rights-of-way of record.

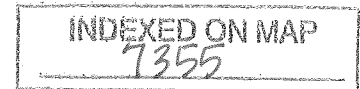



INNOVATIVE IDEAS  
EXCEPTIONAL DESIGN  
UNMATCHED CLIENT SERVICE

Bearings and distances, described herein, are derived from GPS observations based on Grid North, Ohio State Plane Coordinate System, North Zone, NAD83 (2011, Epoch 2010). Distances are expressed in U.S. Survey Feet. All other measurements are from angles and distances measured in a field survey by DLZ on September 21, 2020.

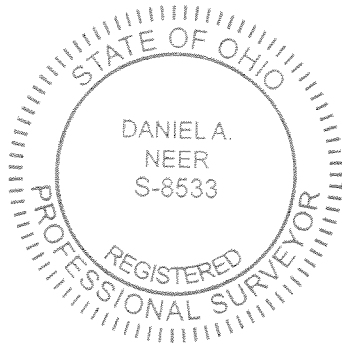

Description prepared by:

Daniel A. Neer  
Professional Surveyor No. 8533  
September 23, 2020

2021-2104.00

INDEXED ON MAP  
7355

10-2-2020



**APPROVED**



ARCHITECTURE • ENGINEERING • PLANNING  
SURVEYING • CONSTRUCTION SERVICES

INNOVATIVE IDEAS  
EXCEPTIONAL DESIGN  
UNMATCHED CLIENT SERVICE

**WON BONG CHA  
TRACT B  
0.295 ACRE**

Lying in Virginia Military Survey 4478, City of Bellefontaine, Jefferson Township, Logan County, Ohio (all records referenced herein refer to the Logan County Records of Deeds).

Being out of the Won Bong Cha 2.203 acre tract as deeded and described in Official Record 1321, Page 195, Tract I, and being more particularly described as follows:

**COMMENCING** at a 5/8 inch iron rebar set at a common northerly corner to Lot 4919 of Belle Pines Subdivision (Plat Cabinet B, Slides 93A & 93B) and said 2.203 acre tract;

**THENCE**, South 85°-28'-25" East, along a common line to the northerly line of said 2.203 acre tract and the southerly right-of-way line of White Pines Drive (60 feet wide), a distance of 101.33 feet to a 5/8 inch iron rebar set and being the **TRUE POINT OF BEGINNING**;

**THENCE**, South 85°-28'-25" East, continuing along said common line, a distance of **100.08 feet** to a 5/8 inch iron rebar set;

**THENCE**, South 04°-31'-35" West, with a new division line through said 2.203 acre tract, a distance of **129.37 feet** to a 5/8 inch iron rebar set on a common line to the northerly line of the William A. Siekierka 4.293 acre tract as deeded and described in Official Record 1322, Page 114, the southerly line of said 2.203 acre tract and the Bellefontaine Corporation line;

**THENCE**, North 84°-10'-16" West, along said common line, a distance of **100.11 feet** to a 5/8 inch iron rebar set;

**THENCE**, North 04°-31'-35" East, with a new division line through said original 2.203 acre tract, a distance of **127.10 feet** to the **POINT OF BEGINNING**.

Containing **0.295 acre**, more or less.

Iron rebar set, where indicated, are 30 inches in length, 5/8 inch in diameter with a plastic I.D. cap stamped "DLZ OHIO INC.".

INDEXED ON MAP  
7355





INNOVATIVE IDEAS  
EXCEPTIONAL DESIGN  
UNMATCHED CLIENT SERVICE

Property is subject to any and all previous easements and rights-of-way of record.

Bearings and distances, described herein, are derived from GPS observations based on Grid North, Ohio State Plane Coordinate System, North Zone, NAD83 (2011, Epoch 2010). Distances are expressed in U.S. Survey Feet. All other measurements are from angles and distances measured in a field survey by DLZ on September 21, 2020.

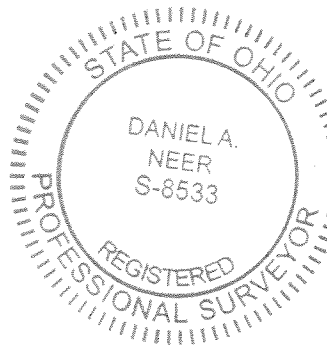

Description prepared by:

Daniel A. Neer  
Professional Surveyor No. 8533  
September 23, 2020

2021-2104.00

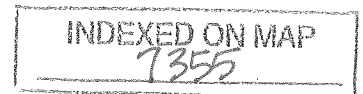

10-2-2020



**APPROVED**



ARCHITECTURE • ENGINEERING • PLANNING  
SURVEYING • CONSTRUCTION SERVICES

INNOVATIVE IDEAS  
EXCEPTIONAL DESIGN  
UNMATCHED CLIENT SERVICE

**WON BONG CHA  
TRACT C  
0.295 ACRE**

Lying in Virginia Military Survey 4478, City of Bellefontaine, Jefferson Township, Logan County, Ohio (all records referenced herein refer to the Logan County Records of Deeds).

Being out of the Won Bong Cha 2.203 acre tract as deeded and described in Official Record 1321, Page 195, Tract I, and being more particularly described as follows:

**COMMENCING** at a 5/8 inch iron rebar set at a common northerly corner to Lot 4919 of Belle Pines Subdivision(Plat Cabinet B, Slides 93A & 93B) and said 2.203 acre tract;

THENCE, South 85°-28'-25" East, along a common line to the northerly line of said 2.203 acre tract and the southerly right-of-way line of White Pines Drive (60 feet wide), a distance of 201.41 feet to a 5/8 inch iron rebar set and being the **TRUE POINT OF BEGINNING**;

THENCE, **South 85°-28'-25" East**, continuing along said common line, a distance of **98.35 feet** to a 5/8 inch iron rebar set;

THENCE, **South 04°-31'-35" West**, with a new division line through said 2.203 acre tract, a distance of **131.61 feet** to a 5/8 inch iron rebar set on a common line to the northerly line of the William A. Siekierka 4.293 acre tract as deeded and described in Official Record 1322, Page 114, the southerly line of said 2.203 acre tract and the Bellefontaine Corporation line;

THENCE, **North 84°-10'-16" West**, along said common line, a distance of **98.38 feet** to a 5/8 inch iron rebar set;

THENCE, **North 04°-31'-35" East**, with a new division line through said original 2.203 acre tract, a distance of **129.37 feet** to the **POINT OF BEGINNING**.

Containing **0.295 acre**, more or less.

Iron rebar set, where indicated, are 30 inches in length, 5/8 inch in diameter with a plastic I.D. cap stamped "DLZ OHIO INC."





INNOVATIVE IDEAS  
EXCEPTIONAL DESIGN  
UNMATCHED CLIENT SERVICE

Property is subject to any and all previous easements and rights-of-way of record.

Bearings and distances, described herein, are derived from GPS observations based on Grid North, Ohio State Plane Coordinate System, North Zone, NAD83 (2011, Epoch 2010). Distances are expressed in U.S. Survey Feet. All other measurements are from angles and distances measured in a field survey by DLZ on September 21, 2020.

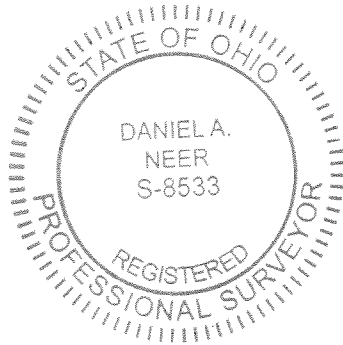

Description prepared by:

Daniel A. Neer  
Professional Surveyor No. 8533  
September 23, 2020

2021-2104.00

INDEXED ON MAP  
7355





INNOVATIVE IDEAS  
EXCEPTIONAL DESIGN  
UNMATCHED CLIENT SERVICE

Property is subject to any and all previous easements and rights-of-way of record.

Bearings and distances, described herein, are derived from GPS observations based on Grid North, Ohio State Plane Coordinate System, North Zone, NAD83 (2011, Epoch 2010). Distances are expressed in U.S. Survey Feet. All other measurements are from angles and distances measured in a field survey by DLZ on September 21, 2020.

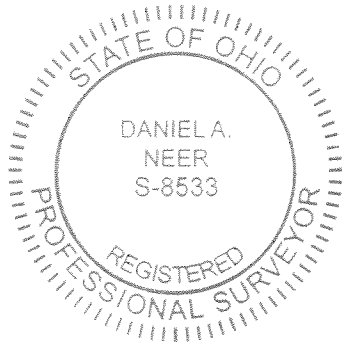

Description prepared by:

Daniel A. Neer  
Professional Surveyor No. 8533  
September 23, 2020

2021-2104.00

INDEXED ON MAP  
7355

10-2-2020



**APPROVED**



ARCHITECTURE • ENGINEERING • PLANNING  
SURVEYING • CONSTRUCTION SERVICES

INNOVATIVE IDEAS  
EXCEPTIONAL DESIGN  
UNMATCHED CLIENT SERVICE

**WON BONG CHA  
TRACT E  
0.294 ACRE**

Lying in Virginia Military Survey 4478, City of Bellefontaine, Jefferson Township, Logan County, Ohio (all records referenced herein refer to the Logan County Records of Deeds).

Being out of the Won Bong Cha original 2.203 acre tract as deeded and described in Official Record 1321, Page 195, Tract I and being more particularly described as follows:

**COMMENCING** at a 5/8 inch iron rebar set at a common northerly corner to Lot 4919 of Belle Pines Subdivision (Plat Cabinet B, Slides 93A & 93B) and said 2.203 acre tract;

THENCE, South 85°-28'-25" East, along a common line to the northerly line of said 2.203 acre tract and the southerly right-of-way line of White Pines Drive (60 feet wide), a distance of 402.08 feet to a 5/8 inch iron rebar set and being the **TRUE POINT OF BEGINNING**;

THENCE, **South 85°-28'-25" East**, continuing along said common line, a distance of **108.83 feet** to a 5/8 inch iron rebar set;

THENCE, with new division lines through said 2.203 acre tract, the following three (3) courses:

- 1) **South 04°-31'-35" West**, a distance of **118.66 feet** to a 5/8 inch iron rebar set;
- 2) **North 84°-33'-59" West**, a distance of **108.85 feet** to a 5/8 inch iron rebar set; and
- 3) **North 04°-31'-35" East**, a distance of **116.93 feet** to the **POINT OF BEGINNING**.

Containing **0.294 acre**, more or less.

Iron rebar set, where indicated, are 30 inches in length, 5/8 inch in diameter with a plastic I.D. cap stamped "DLZ OHIO INC."

Property is subject to any and all previous easements and rights-of-way of record.





INNOVATIVE IDEAS  
EXCEPTIONAL DESIGN  
UNMATCHED CLIENT SERVICE

Bearings and distances, described herein, are derived from GPS observations based on Grid North, Ohio State Plane Coordinate System, North Zone, NAD83 (2011, Epoch 2010). Distances are expressed in U.S. Survey Feet. All other measurements are from angles and distances measured in a field survey by DLZ on September 21, 2020.

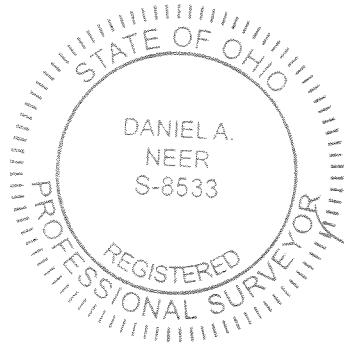

Description prepared by:

*Daniel A. Neer*  
Daniel A. Neer  
Professional Surveyor No. 8533  
September 23, 2020

2021-2104.00

INDEXED ON MAP  
7355

10-2-2020



INNOVATIVE IDEAS  
EXCEPTIONAL DESIGN  
UNMATCHED CLIENT SERVICE

**WON BONG CHA  
TRACT F  
0.295 ACRE**

Lying in Virginia Military Survey 4478, City of Bellefontaine, Jefferson Township, Logan County, Ohio (all records referenced herein refer to the Logan County Records of Deeds).

Being out of the Won Bong Cha 2.203 acre tract as deeded and described in Official Record 1321, Page 195, Tract I, and being more particularly described as follows:

**COMMENCING** at a 5/8 inch iron rebar set at a common northerly corner to Lot 4919 of Belle Pines Subdivision (Plat Cabinet B, Slides 93A & 93B) and said 2.203 acre;

THENCE, South 85°-28'-25" East, along a common line to the northerly line of said 2.203 acre tract and the southerly right-of-way line of White Pines Drive (60 feet wide), a distance of 510.91 feet to a 5/8 inch iron rebar set and being the **TRUE POINT OF BEGINNING**;

THENCE, **South 85°-28'-25" East**, continuing along said common line, a distance of **54.78 feet** to a 5/8 inch iron rebar found (I.D. cap "LEE");

THENCE, **South 84°-56'-46" East**, continuing along said common line, a distance of **53.24 feet** to a 5/8 inch iron rebar set;

THENCE, with new division lines through said 2.203 acre tract, the following three (3) courses:

- 1) **South 05°-03'-33" West**, a distance of **119.87 feet** to a 5/8 inch iron rebar set; and
- 2) **North 84°-33'-59" West**, a distance of **106.92 feet** to a 5/8 inch iron rebar set;
- 3) **North 04°-31'-35" East**, a distance of **118.66 feet** to the **POINT OF BEGINNING**.

Containing **0.295 acre**, more or less.

Iron rebar set, where indicated, are 30 inches in length, 5/8 inch in diameter with a plastic I.D. cap stamped "DLZ OHIO INC.".





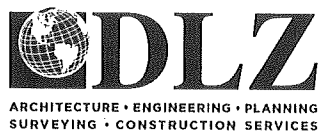

INNOVATIVE IDEAS  
EXCEPTIONAL DESIGN  
UNMATCHED CLIENT SERVICE

Property is subject to any and all previous easements and rights-of-way of record.

Bearings and distances, described herein, are derived from GPS observations based on Grid North, Ohio State Plane Coordinate System, North Zone, NAD83 (2011, Epoch 2010). Distances are expressed in U.S. Survey Feet. All other measurements are from angles and distances measured in a field survey by DLZ on September 21, 2020.

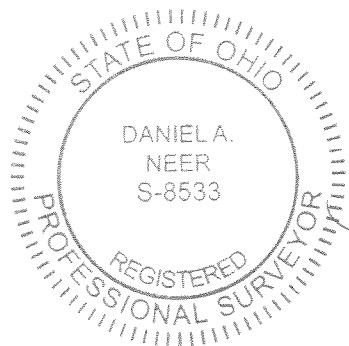

Description prepared by:

*D. Neer*  
Daniel A. Neer  
Professional Surveyor No. 8533  
September 23, 2020

2021-2104.00

INDEXED ON MAP  
7355

10-2-2020



**APPROVED**



INNOVATIVE IDEAS  
EXCEPTIONAL DESIGN  
UNMATCHED CLIENT SERVICE

**WON BONG CHA  
TRACT G  
0.294 ACRE**

Lying in Virginia Military Survey 4478, City of Bellefontaine, Jefferson Township, Logan County, Ohio (all records referenced herein refer to the Logan County Records of Deeds).

Being out of the Won Bong Cha 2.203 acre tract as deeded and described in Official Record 1321, Page 195, Tract I, and out of the Estate of Won Bong Cha 0.365 acre tract as deeded and described in Official Record 1353, Page 868 and being more particularly described as follows:

**COMMENCING** at a 5/8 inch iron rebar set at a common northerly corner to Lot 4919 of Belle Pines Subdivision (Plat Cabinet B, Slides 93A & 93B) and said 2.203 acre tract;

**THENCE**, South 85°-28'-25" East, along a common line to the northerly line of said 2.203 acre tract and the southerly right-of-way line of White Pines Drive (60 feet wide), a distance of 565.69 feet to a 5/8 inch iron rebar found (I.D. cap "LEE");

**THENCE**, South 84°-56'-46" East, continuing along said common line, a distance of 53.24 feet to a 5/8 inch iron rebar set and being the **TRUE POINT OF BEGINNING**;

**THENCE**, **South 84°-56'-46" East**, along a common line to the northerly lines of said 2.203 acre and 0.365 acre tracts and the southerly right-of-way line of said White Pines Drive, a distance of **106.50 feet** to a 5/8 inch iron rebar set;

**THENCE**, **South 05°-03'-14" West**, with a new division line through said 0.365 acre tract, a distance of **120.57 feet** to a 5/8 inch iron rebar set;

**THENCE**, **North 84°-33'-59" West**, with a new division line through said 0.365 acre and 2.203 acre tracts, a distance of **106.52 feet** to a 5/8 inch iron rebar set;

**THENCE**, **North 05°-03'-33" East**, with a new division line through said 2.203 acre tract, a distance of **119.87 feet** to the **POINT OF BEGINNING**.

INDEXED ON MAP  
1355



INNOVATIVE IDEAS  
EXCEPTIONAL DESIGN  
UNMATCHED CLIENT SERVICE

Containing **0.294 acre**, more or less, of which 0.274 acre are out of said 2.203 acre tract and **0.020 acre** are out of said 0.365 acre tract.

Iron rebar set, where indicated, are 30 inches in length, 5/8 inch in diameter with a plastic I.D. cap stamped "DLZ OHIO INC."

Property is subject to any and all previous easements and rights-of-way of record.

Bearings and distances, described herein, are derived from GPS observations based on Grid North, Ohio State Plane Coordinate System, North Zone, NAD83 (2011, Epoch 2010). Distances are expressed in U.S. Survey Feet. All other measurements are from angles and distances measured in a field survey by DLZ on September 21, 2020.

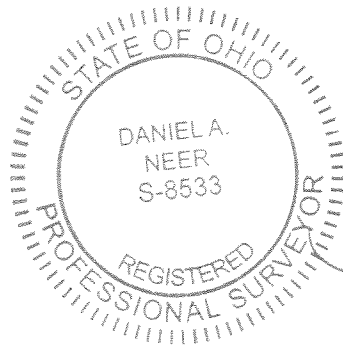

Description prepared by:

*Daniel A. Neer*  
Daniel A. Neer  
Professional Surveyor No. 8533  
September 17, 2020

2021-2104.00

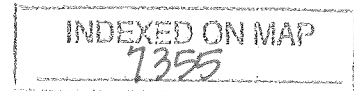

10-2-2020

✓ APPROVED



INNOVATIVE IDEAS  
EXCEPTIONAL DESIGN  
UNMATCHED CLIENT SERVICE

**WON BONG CHA  
TRACT H  
0.293 ACRE**

Lying in Virginia Military Survey 4478, City of Bellefontaine, Jefferson Township, Logan County, Ohio (all records referenced herein refer to the Logan County Records of Deeds).

Being out of the Estate of Won Bong Cha original 0.365 acre tract as deeded and described in Official Record 1353, Page 868 and being more particularly described as follows:

**COMMENCING** at a 5/8 inch iron rebar set at a common northerly corner to Lot 4919 of Belle Pines Subdivision (Plat Cabinet B, Slides 93A & 93B) and the northerly corner of the Won Bong Cha 2.203 acre tract as deeded and described in Official Record 1321, Page 205, Tract II;

THENCE, South 85°-28'-25" East, along a common line to the northerly line of said 2.203 acre tract and the southerly right-of-way line of White Pines Drive (60 feet wide), a distance of 565.69 feet to a 5/8 inch iron rebar found (I.D. cap "LEE");

THENCE, South 84°-56'-46" East, along a common line to the northerly line of said 2.203 acre tract, the northerly line of said 0.365 acre tract, and southerly right-of-way line of said White Pines Drive, a distance of 159.74 feet to a 5/8 inch iron rebar set and being the **TRUE POINT OF BEGINNING**;

THENCE, **South 84°-56'-46" East**, along a common line to the northerly line of said 0.365 acre tract and the southerly right-of-way line of said White Pines Drive, a distance of **81.80 feet** to a 5/8 inch iron rebar found (I.D. cap "LEE") on the arc of a curve;

THENCE, continuing along said common line, with the arc of said curve, to the right, having a central angle of 89°-59'-45", a radius of 25.00 feet, an arc length of 39.27 feet, a chord bearing and distance of **South 39°-56'-54" East, 35.35 feet** to a point on a common line to the easterly line of said 0.365 acre tract and the westerly right-of-way line of Township Road 179 (60 feet wide), said point being referenced by a 5/8 inch iron rebar found bearing South 79°-21'-35" East, a distance of 0.09';

INDEXED ON MAP  
7355



INNOVATIVE IDEAS  
EXCEPTIONAL DESIGN  
UNMATCHED CLIENT SERVICE

THENCE, **South 05°-02'-59" West**, along said common line, a distance of **96.28 feet** to a 5/8 inch iron rebar set;

THENCE, **North 84°-33'-59" West**, with a new division line through said 0.356 acre tract, a distance of **106.81 feet** to a 5/8 inch iron rebar set;

THENCE, **North 05°-03'-14" East**, with a new division line through said 0.365 acre tract, a distance of **120.57 feet** to the **POINT OF BEGINNING**.

Containing **0.293 acre**, more or less.

Iron rebar set, where indicated, are 30 inches in length, 5/8 inch in diameter with a plastic I.D. cap stamped "DLZ OHIO INC.".

Property is subject to any and all previous easements and rights-of-way of record.

Bearings and distances, described herein, are derived from GPS observations based on Grid North, Ohio State Plane Coordinate System, North Zone, NAD83 (2011, Epoch 2010). Distances are expressed in U.S. Survey Feet. All other measurements are from angles and distances measured in a field survey by DLZ on September 21, 2020.

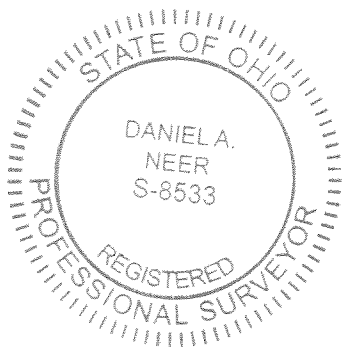

Description prepared by:

Daniel A. Neer  
Professional Surveyor No. 8533  
September 23, 2020

2021-2104.00

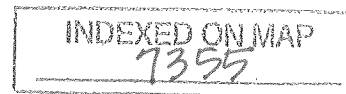

10-2-2020

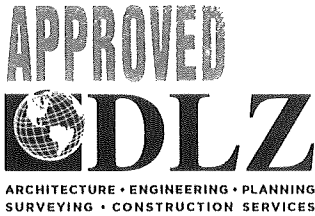

INNOVATIVE IDEAS  
EXCEPTIONAL DESIGN  
UNMATCHED CLIENT SERVICE

## PROPOSED 20' UTILITY EASEMENT 0.383 ACRE

Lying in Virginia Military Survey 4478, (partly in the City of Bellefontaine), Jefferson Township, Logan County, Ohio (all records referenced herein refer to the Logan County Records of Deeds).

Being a 20 feet wide utility easement across the Wong Bong Cha 2.203 acre tract as deeded and described in Official Record 1321, Page 195, Tract I, the Estate of Won Bong Cha 0.365 acre tract as deeded and described in Official Record 1353, Page 868 and the William A. Siekierka 4.293 acre tract as deeded and described in Official Record 1322, Page 114 and the centerline of said 20 feet wide utility easement being more particularly described as follows:

**COMMENCING** at a 5/8 inch iron rebar set at a common northerly corner to Lot 4919 of Belle Pines Subdivision (Plat Cabinet B, Slides 93A & 93B) and Won Bong Cha 2.203 acre tract as deeded and described in Official Record 1321, Page 195, Tract I;

**THENCE**, South 05°-03'-14" West, along a common line to the westerly line of said 2.203 acre tract and the easterly line of said Lot 4919, a distance of 124.77 feet to a 5/8 inch iron rebar found (I.D. cap "LEE") at the **TRUE POINT OF BEGINNING**;

**THENCE**, South 84°-10'-16" East, along a common line to the southerly line of said 2.203 acre tract, the northerly line of the William A. Siekierka 4.293 acre tract as deeded and described in Official Record 1322, Page 114 and the Bellefontaine Corporation line, a distance of **301.00 feet** to a 5/8 inch iron rebar set;

**THENCE**, North 86°-21'-55" East, across said 2.203 acre tract, a distance of **103.37 feet** to a 5/8 inch iron rebar set;

**THENCE**, South 84°-33'-59" East, across said 2.203 acre and 0.365 acre tracts, a distance of **429.10 feet** to the **POINT OF TERMINUS**.

Containing **0.383 acre**, more or less and the sidelines of which extend or terminate at angle points or property lines.

Iron rebar set, where indicated, are 30 inches in length, 5/8 inch in diameter with a plastic I.D. cap stamped "DLZ OHIO INC.".



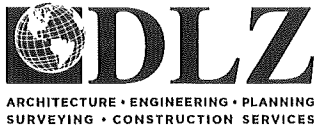

INNOVATIVE IDEAS  
EXCEPTIONAL DESIGN  
UNMATCHED CLIENT SERVICE

Property is subject to any and all previous easements and rights-of-way of record.

Bearings and distances, described herein, are derived from GPS observations based on Grid North, Ohio State Plane Coordinate System, North Zone, NAD83 (2011, Epoch 2010). Distances are expressed in U.S. Survey Feet. All other measurements are from angles and distances measured in a field survey by DLZ on September 21, 2020.

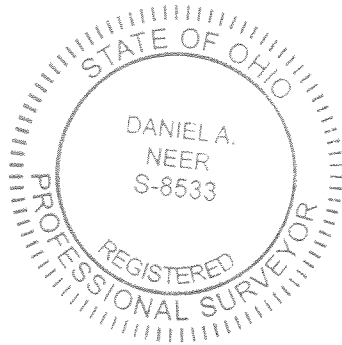

Description prepared by:

Daniel A. Neer  
Professional Surveyor No. 8533  
September 29, 2020

2021-2104.00

INDEXED ON MAP  
7355

10-2-2020



INNOVATIVE IDEAS  
EXCEPTIONAL DESIGN  
UNMATCHED CLIENT SERVICE

## WON BONG CHA 0.202 ACRE

Lying in Virginia Military Survey 4478, City of Bellefontaine, Jefferson Township, Logan County, Ohio (all records referenced herein refer to the Logan County Records of Deeds).

Being out of the Won Bong Cha 2.203 acre tract as deeded and described in Official Record 1321, Page 195, Tract I, and out of the Estate of Won Bong Cha 0.365 acre tract as deeded and described in Official Record 1353, Page 868 and being more particularly described as follows:

**COMMENCING** at a 5/8 inch iron rebar set at a common northerly corner to Lot 4919 of Belle Pines Subdivision (Plat Cabinet B, Slides 93A & 93B) and said 2.203 acre tract;

THENCE, South 05°-03'-14" West, along a common line to the westerly line of said 2.203 acre tract and the easterly line of said Lot 4919, a distance of 124.77 feet to a 5/8 inch iron rebar found (I.D. cap "LEE");

THENCE, South 84°-10'-16" East, along a common line to the southerly line of said 2.203 acre tract, the northerly line of the William A. Siekierka 4.293 acre tract as deeded and described in Official Record 1322, Page 114 and the Bellefontaine Corporation line, a distance of 301.00 feet to a 5/8 inch iron rebar set and being the **TRUE POINT OF BEGINNING**;

THENCE, North 86°-21'-55" East, with a new division line through said 2.203 acre tract, a distance of **103.37 feet** to a 5/8 inch iron rebar set;

THENCE, South 84°-33'-59" East, with a new division line through said 2.203 acre tract and said 0.365 acre tract, a distance of **429.10 feet** to a 5/8 inch iron rebar set on the westerly right-of-way line of Township Road 179 (60 feet wide);

THENCE, South 05°-02'-59" West, along a common line to the easterly line of said 0.365 acre tract and said westerly right of way line, a distance of **20.00 feet** to a point on the northerly line of the Lori D. Edwards 3.207 acre tract as deeded and described in Official Record 177, Page 820, said point being referenced by a 3/4 inch iron pipe found bearing South 84°-29'-51" East, a distance of 0.11 feet;







INNOVATIVE IDEAS  
EXCEPTIONAL DESIGN  
UNMATCHED CLIENT SERVICE

THENCE, **North 84°-09'-50" West**, along a common line to the northerly line of said 3.207 acre tract, the southerly line of said 0.365 acre tract, and the southerly line of said 2.203 acre tract and the Bellefontaine Corporation line, a distance of **333.10 feet** to a 5/8 inch iron rebar set at a common corner to the northeast corner of said 4.293 acre tract and the northwest corner of said 3.207 acre tract;

THENCE, **North 84°-10'-16" West**, along a common line to the northerly line of said 4.293 acre tract and the southerly line of said 2.203 acre tract and the Bellefontaine Corporation line, a distance of **198.22 feet** to the **POINT OF BEGINNING**.

Containing **0.202 acre**, more or less, of which 0.151 acre are out of said 2.203 acre tract and 0.051 acre are out of said 0.365 acre tract.

Iron rebar set, where indicated, are 30 inches in length, 5/8 inch in diameter with a plastic I.D. cap stamped "DLZ OHIO INC.".

Property is subject to any and all previous easements and rights-of-way of record.

Bearings and distances, described herein, are derived from GPS observations based on Grid North, Ohio State Plane Coordinate System, North Zone, NAD83 (2011, Epoch 2010). Distances are expressed in U.S. Survey Feet. All other measurements are from angles and distances measured in a field survey by DLZ on September 21, 2020.

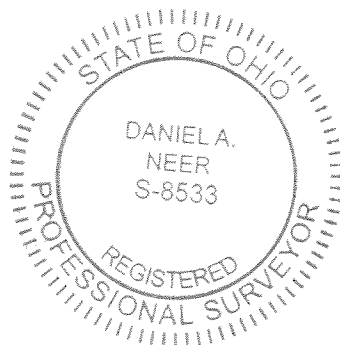

Description prepared by:

Daniel A. Neer  
Professional Surveyor No. 8533  
September 23, 2020

2021-2104.00



10-2-2020



**APPROVED**



INNOVATIVE IDEAS  
EXCEPTIONAL DESIGN  
UNMATCHED CLIENT SERVICE

**LORI D. EDWARDS  
0.125 ACRE**

Lying in Virginia Military Survey 4478, Jefferson Township, Logan County, Ohio (all records referenced herein refer to the Logan County Records of Deeds).

Being out of the Lori D. Edwards 3.207 acre tract as deeded and described in Official Record 177, Page 820, and being more particularly described as follows:

**COMMENCING** at a 5/8 inch iron rebar set at a common northerly corner to Lot 4919 of Belle Pines Subdivision (Plat Cabinet B, Slides 93A & 93B) and Won Bong Cha 2.203 acre tract as deeded and described in Official Record 1321, Page 195, Tract I;

**THENCE**, South 05°-03'-14" West, along a common line to the westerly line of said 2.203 acre tract and the easterly line of said Lot 4919, a distance of 124.77 feet to a 5/8 inch iron rebar found (I.D. cap "LEE");

**THENCE**, South 84°-10'-16" East, along a common line to the southerly line of said 2.203 acre tract, the northerly line of the William A. Siekierka 4.293 acre tract as deeded and described in Official Record 1322, Page 114 and the Bellefontaine Corporation line, a distance of 499.22 feet to a 5/8 inch iron rebar set at the northeast corner of said 3.207 acre tract and being the **TRUE POINT OF BEGINNING**;

**THENCE**, South 84°-09'-50" East, along a common line to the northerly line of said 3.207 acre tract, the southerly lines of said 2.203 acre tract and the Estate of Won Bong Cha 0.365 acre tract as deeded and described in Official Record 1353, Page 868, and said Bellefontaine Corporation line, passing a 3/4 inch iron pipe found at a distance of 333.21 feet, a total distance of **363.10** feet to a 5/8 inch iron rebar found on the centerline of Township Road 179(60 feet wide);

**THENCE**, South 05°-02'-59" West, along the common line to the centerline of Township Road 179 and the east line of said 3.207 acre tract, a distance of **15.00** feet to a mag nail set;

**THENCE**, North 84°-09'-50" West, with a new division line through

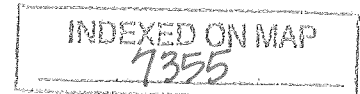



INNOVATIVE IDEAS  
EXCEPTIONAL DESIGN  
UNMATCHED CLIENT SERVICE

said 3.207 acre tract, passing a 5/8 inch iron rebar set at a distance of 30.00 feet, a total distance of **363.73 feet** to a 5/8 inch iron rebar set on the common line to the easterly line of said 4.293 acre tract and the westerly line of said 3.207 acre tract ;

THENCE, **North 07°-24'-36" East**, along said common line, a distance of **15.01 feet** to the **POINT OF BEGINNING**.

Containing **0.125 acre**, more or less.

Iron rebar set, where indicated, are 30 inches in length, 5/8 inch in diameter with a plastic I.D. cap stamped "DLZ OHIO INC.".

Property is subject to any and all previous easements and rights -of-way of record.

Bearings and distances, described herein, are derived from GPS observations based on Grid North, Ohio State Plane Coordinate System, North Zone, NAD83 (2011, Epoch 2010). Distances are expressed in U.S. Survey Feet. All other measurements are from angles and distances measured in a field survey by DLZ on September 21, 2020.



Description prepared by:

  
Daniel A. Neer  
Professional Surveyor No. 8533  
September 23, 2020

2021-2104.00

INDEXED ON MAP  
7355

**APPROVED**

**DEED & SURVEY REFERENCES:**

REFERENCE DEEDS ARE SHOWN HEREON

LOGAN COUNTY ENGINEER'S MAP ROOM  
FILES: 2645, 1360, 5469, 8585, 8281,  
6864 AND 9336

- ① ESTATE OF WON BONG CHA  
O.R. 1353, PG. 868  
0.365 ACRE
- ② WON BONG CHA  
O.R. 1321, PG. 195  
TRACT I-2.203 ACRES

**BASIS FOR BEARINGS:**

BEARINGS AND DISTANCES, SHOWN HEREON,  
ARE DERIVED FROM GPS OBSERVATIONS  
BASED ON GRID NORTH, OHIO STATE PLANE  
COORDINATE SYSTEM, NORTH ZONE, NAD83  
(2011, EPOCH 2010).

**OCCUPATION NOTE:**

NO EVIDENCE OF OCCUPATION ALONG  
BOUNDARY LINES, UNLESS OTHERWISE  
SHOWN HEREON.

- ③ P.O.B. TRACT B
- ④ P.O.B. TRACT C
- ⑤ P.O.B. TRACT D
- ⑥ P.O.B. TRACT E
- ⑦ P.O.B. TRACT F
- ⑧ P.O.B. TRACT G
- ⑨ P.O.B. TRACT H

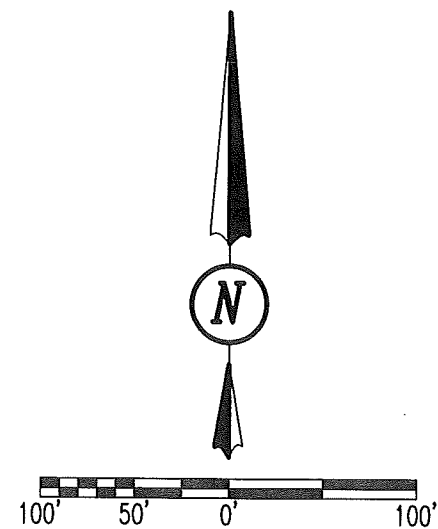

SCALE: 1" = 100'  
DISTANCES SHOWN HEREON  
ARE IN U.S. SURVEY FEET

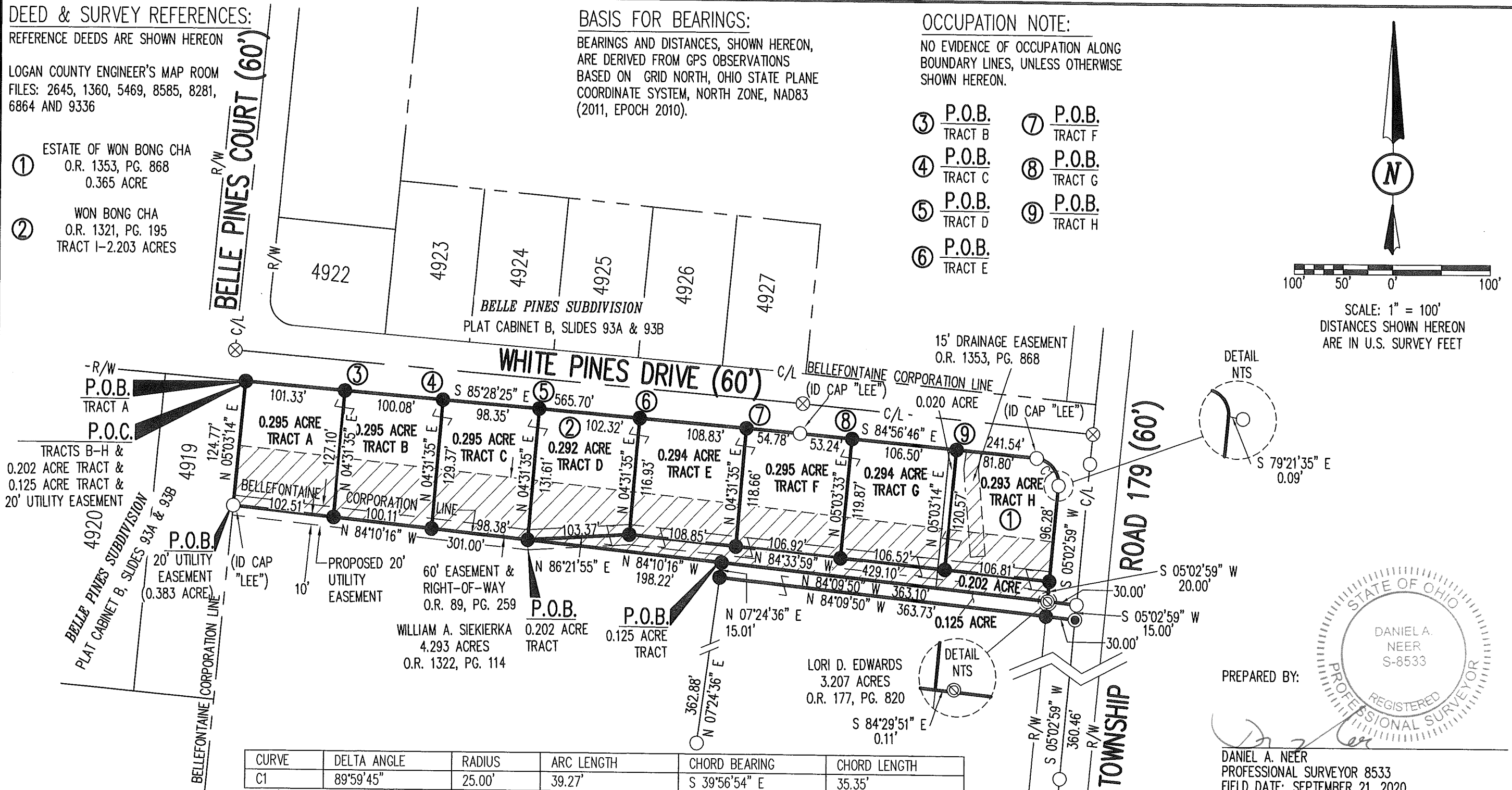

CURVE	DELTA ANGLE	RADIUS	ARC LENGTH	CHORD BEARING	CHORD LENGTH
C1	89°59'45"	25.00'	39.27'	S 39°56'54" E	35.35'

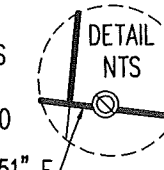
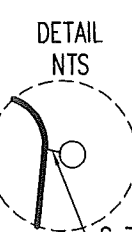

PREPARED BY:  
*[Signature]*

DANIEL A. NEER  
PROFESSIONAL SURVEYOR 8533  
FIELD DATE: SEPTEMBER 21, 2020

COPYRIGHT 2020 BY:

117 N. Madriver Street • Bellefontaine, OH 43311  
(937) 593-7335 • www.dlz.com  
Project #2021-2104.00

**LEGEND**

⊙ 3/4 INCH IRON PIPE FOUND	C/L = CENTERLINE
⊗ RAILROAD SPIKE FOUND	R/W = RIGHT-OF-WAY
● MAG NAIL SET	O.R. = OFFICIAL RECORD
● 5/8 INCH BY 30 INCH IRON REBAR SET WITH PLASTIC I.D. CAP STAMPED "DLZ OHIO INC."	PG. = PAGE
○ 5/8 INCH IRON REBAR FOUND	P.O.B. = POINT OF BEGINNING
	P.O.C. = POINT OF COMMENCEMENT
	NTS = NOT TO SCALE

**BOUNDARY SURVEY**  
VIRGINIA MILITARY SURVEY 4478  
CITY OF BELLEFONTAINE  
JEFFERSON TOWNSHIP  
LOGAN COUNTY, OHIO

DRAWN BY:	DESCRIPTION	REV. NO.	DATE
DAN			9/1/2020
DCC			9/22/2020

INDEXED ON MAP  
7355



INNOVATIVE IDEAS  
EXCEPTIONAL DESIGN  
UNMATCHED CLIENT SERVICE

**RPM ENGINEERING LLC  
TRACT A  
0.295 ACRE**

Lying in Virginia Military Survey 4478, City of Bellefontaine, Jefferson Township, Logan County, Ohio (all records referenced herein refer to the Logan County Records of Deeds).

Being out of the RPM Engineering LLC 2.203 acre tract as deeded and described in Official Record 1392, Page 3727, and being more particularly described as follows:

**COMMENCING** at a 5/8 inch iron rebar set at a common northerly corner to Lot 4919 of Belle Pines Subdivision (Plat Cabinet B, Slides 93A & 93B) and said 2.203 acre tract;

**THENCE**, South 85°-11'-32" East, along a common line to the northerly line of said 2.203 acre tract and the southerly right-of-way line of White Pines Drive (60 feet wide), a distance of 101.33 feet to a 5/8 inch iron rebar set and being the **TRUE POINT OF BEGINNING**;

**THENCE**, South 85°-11'-32" East, continuing along said common line, a distance of **100.08 feet** to a 5/8 inch iron rebar set;

**THENCE**, South 04°-48'-28" West, with a new division line through said 2.203 acre tract, a distance of **129.35 feet** to a 5/8 inch iron rebar set on a common line to the northerly line of the William A. Siekierka 4.293 acre tract as deeded and described in Official Record 1322, Page 114, the southerly line of said 2.203 acre tract and the Bellefontaine Corporation line;

**THENCE**, North 83°-53'-34" West, along said common line, a distance of **100.11 feet** to a 5/8 inch iron rebar set;

**THENCE**, North 04°-48'-28" East, with a new division line through said original 2.203 acre tract, a distance of **127.08 feet** to the **POINT OF BEGINNING**.

Containing **0.295 acre**, more or less.

Iron rebar set, where indicated, are 30 inches in length, 5/8 inch in diameter with a plastic I.D. cap stamped "DLZ OHIO INC."

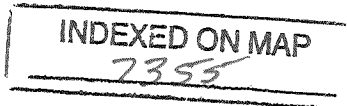

117 N Madriver St, Bellefontaine, OH 43311 | OFFICE 937.593.7335 | ONLINE WWW.DLZ.COM



**APPROVED**



**DLZ**

ARCHITECTURE • ENGINEERING • PLANNING  
SURVEYING • CONSTRUCTION SERVICES

INNOVATIVE IDEAS  
EXCEPTIONAL DESIGN  
UNMATCHED CLIENT SERVICE

Property is subject to any and all previous easements and rights-of-way of record.

Bearings and distances, described herein, are derived from GPS observations based on Grid North, Ohio State Plane Coordinate System, North Zone, NAD83 (2011, Epoch 2010). Distances are expressed in U.S. Survey Feet. All other measurements are from angles and distances measured in a field survey by DLZ on September 21, 2020.

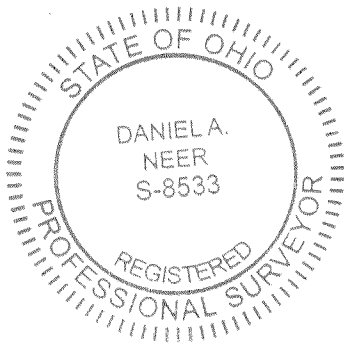

Description prepared by:

Daniel A. Neer  
Professional Surveyor No. 8533  
October 14, 2020

INDEXED ON MAP  
7353

2021-2104.00



**APPROVED**



INNOVATIVE IDEAS  
EXCEPTIONAL DESIGN  
UNMATCHED CLIENT SERVICE

**RPM ENGINEERING LLC  
TRACT B  
0.295 ACRE**

Lying in Virginia Military Survey 4478, City of Bellefontaine, Jefferson Township, Logan County, Ohio (all records referenced herein refer to the Logan County Records of Deeds).

Being out of the RPM Engineering LLC 2.203 acre tract as deeded and described in Official Record 1392, Page 3727, and being more particularly described as follows:

**COMMENCING** at a 5/8 inch iron rebar set at a common northerly corner to Lot 4919 of Belle Pines Subdivision(Plat Cabinet B, Slides 93A & 93B) and said 2.203 acre tract;

**THENCE**, South 85°-11'-32" East, along a common line to the northerly line of said 2.203 acre tract and the southerly right-of-way line of White Pines Drive (60 feet wide), a distance of 201.41 feet to a 5/8 inch iron rebar set and being the **TRUE POINT OF BEGINNING**;

**THENCE**, South 85°-11'-32" East, continuing along said common line, a distance of **98.35 feet** to a 5/8 inch iron rebar set;

**THENCE**, South 04°-48'-28" West, with a new division line through said 2.203 acre tract, a distance of **131.58 feet** to a 5/8 inch iron rebar set on a common line to the northerly line of the William A. Siekierka 4.293 acre tract as deeded and described in Official Record 1322, Page 114, the southerly line of said 2.203 acre tract and the Bellefontaine Corporation line;

**THENCE**, North 83°-53'-34" West, along said common line, a distance of **98.38 feet** to a 5/8 inch iron rebar set;

**THENCE**, North 04°-48'-28" East, with a new division line through said original 2.203 acre tract, a distance of **129.35 feet** to the **POINT OF BEGINNING**.

Containing **0.295 acre**, more or less.

Iron rebar set, where indicated, are 30 inches in length, 5/8 inch in diameter with a plastic I.D. cap stamped "DLZ OHIO INC."

**INDEXED ON MAP**  
2355

117 N Madriver St, Bellefontaine, OH 43311 | OFFICE 937.593.7335 | ONLINE WWW.DLZ.COM

Akron Bellefontaine Bridgeville Burns Harbor Chicago Cincinnati Cleveland Columbus Detroit Flint Fort Wayne Indianapolis Joliet Kalamazoo Lansing Lexington Louisville Madison Melvindale Munster Muskegon Pittsburgh Port Huron Saint Joseph South Bend Toledo Waterford

✓ APPROVED



INNOVATIVE IDEAS  
EXCEPTIONAL DESIGN  
UNMATCHED CLIENT SERVICE

Property is subject to any and all previous easements and rights-of-way of record.

Bearings and distances, described herein, are derived from GPS observations based on Grid North, Ohio State Plane Coordinate System, North Zone, NAD83 (2011, Epoch 2010). Distances are expressed in U.S. Survey Feet. All other measurements are from angles and distances measured in a field survey by DLZ on September 21, 2020.

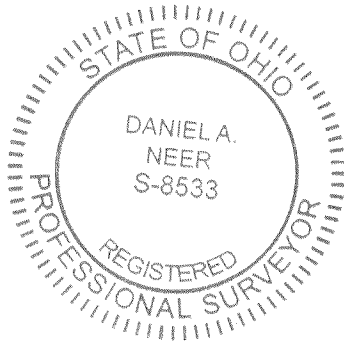

Description prepared by:

Daniel A. Neer  
Professional Surveyor No. 8533  
October 14, 2020

INDEXED ON MAP  
7355

2021-2104.00





**APPROVED**



INNOVATIVE IDEAS  
EXCEPTIONAL DESIGN  
UNMATCHED CLIENT SERVICE

**RPM ENGINEERING LLC  
0.202 ACRE**

Lying in Virginia Military Survey 4478, City of Bellefontaine, Jefferson Township, Logan County, Ohio (all records referenced herein refer to the Logan County Records of Deeds).

Being out of the RPM Engineering LLC 2.203 acre tract as deeded and described in Official Record 1392, Page 3727, and out of the RPM Engineering LLC 0.365 acre tract as deeded and described in Official Record 1392, Page 3655 and being more particularly described as follows:

**COMMENCING** at a railroad spike found at the centerline intersection of Township Road 179 (60 feet wide) and White Pines Drive (60 feet wide);

**THENCE**, South 05°-19'-39" West, along said centerline of Township Road 179, passing a 5/8 inch iron rebar found at a distance of 30.05 feet, a total distance of 171.64 feet to a 5/8 inch iron rebar found at the northeast corner of the RPM Engineering LLC 0.125 acre tract as deeded and described in Official Record 1392, Page 3771;

**THENCE**, North 83°-53'-30" West, along the northerly line of said 0.125 acre tract, passing a 3/4 inch iron pipe found at a distance of 29.89 feet, a total distance of 30.00 feet to a point on the east right-of-way line of said Township Road 179, at the southeast corner of said 0.365 acre tract and being the **TRUE POINT OF BEGINNING**;

**THENCE**, North 83°-53'-30" West, along the northerly line of said 0.125 acre tract and southerly lines of said 0.365 acre and 2.203 acre tracts and the Bellefontaine Corporation Line, a distance of 333.07 feet to a 5/8 inch iron rebar set at the northwesterly corner of the William A. Siekierka 4.293 acre tract as deeded and described in Official Record 1322, Page 114;

**THENCE**, North 83°-53'-34" West, along a common line to the northerly line of said 4.293 acre tract and the southerly lines of said 2.203 acre tract and the Bellefontaine Corporation line, a distance of **198.16 feet** to a 5/8 inch iron rebar set;

**THENCE**, North 86°-39'-19" East, with a new division line through said 2.203 acre tract, a distance of **103.31 feet** to a 5/8 inch iron rebar set;

INDEXED ON MAP  
7355

117 N. Madison St., Bellefontaine, OH 43311

OFFICE 937.593.7335

ONLINE WWW.DLZ.COM



INNOVATIVE IDEAS  
EXCEPTIONAL DESIGN  
UNMATCHED CLIENT SERVICE

THENCE, South 84°-17'-25" East, with a new division line through said 2.203 acre tract and said 0.365 acre tract, a distance of 429.06 feet to a 5/8 inch iron rebar set on a common line to the westerly right-of-way line of Township Road 179 (60 feet wide) and the easterly line of said 0.365 acre tract;

THENCE, South 05°-19'-39" West, along said common line, a distance of 19.95 feet to the POINT OF BEGINNING.

Containing 0.202 acre, more or less, of which 0.151 acre are out of said 2.203 acre tract and 0.051 acre are out of said 0.365 acre tract.

Iron rebar set, where indicated, are 30 inches in length, 5/8 inch in diameter with a plastic I.D. cap stamped "DLZ OHIO INC."

Property is subject to any and all previous easements and rights-of-way of record.

Bearings and distances, described herein, are derived from GPS observations based on Grid North, Ohio State Plane Coordinate System, North Zone, NAD83 (2011, Epoch 2010). Distances are expressed in U.S. Survey Feet. All other measurements are from angles and distances measured in a field survey by DLZ on September 21, 2020.

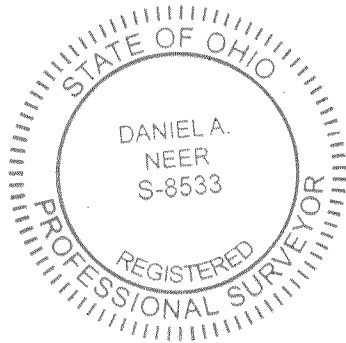

Description prepared by:

Daniel A. Neer  
Professional Surveyor No. 8533  
October 14, 2020

2021-2104.00

INDEXED ON MAP  
7355

10-21-2020



**APPROVED**



ARCHITECTURE • ENGINEERING • PLANNING  
SURVEYING • CONSTRUCTION SERVICES

INNOVATIVE IDEAS  
EXCEPTIONAL DESIGN  
UNMATCHED CLIENT SERVICE

**LORI D. EDWARDS  
0.125 ACRE**

Lying in Virginia Military Survey 4478, Jefferson Township, Logan County, Ohio (all records referenced herein refer to the Logan County Records of Deeds).

Being out of the Lori D. Edwards 3.207 acre tract as deeded and described in Official Record 177, Page 820, and being more particularly described as follows:

**COMMENCING** at a railroad spike found at the centerline intersection of Township Road 179 (60 feet wide) and White Pines Drive (60 feet wide);

**THENCE**, South 05°-19'-39" West, along said centerline of Township Road 179, passing a 5/8 inch iron rebar found at a distance of 30.05 feet, a total distance of 171.64 feet to a 5/8 inch iron rebar found at the northeast corner of said 3.207 acre tract and being the **TRUE POINT OF BEGINNING**;

**THENCE**, South 05°-19'-39" West, along the common line to the centerline of Township Road 179 and the east line of said 3.207 acre tract, a distance of **15.00 feet** to a mag nail set;

**THENCE**, North 83°-53'-30" West, with a new division line through said 3.207 acre tract, passing a 5/8 inch iron rebar set at a distance of 30.00 feet, a total distance of **363.69 feet** to a 5/8 inch iron rebar set on the common line to the easterly line of the William A. Siekierka 4.293 acre tract as deeded and described in Official Record 1322, Page 114 and the westerly line of said 3.207 acre tract;

**THENCE**, North 07°-41'-26" East, along said common line, a distance of **15.01 feet** to a 5/8 inch iron rebar set on a common southerly line to the Won Bong Cha 2.203 acre tract as deeded and described in Official Record 1321, Page 195, Tract I, and the Bellefontaine Corporation Line;

**THENCE**, South 83°-53'-30" East, along the northerly line of said 3.207 acre tract, said common southerly line and the southerly line of the Estate of Won Bong Cha 0.365 acre tract as deeded and described in Official Record 1353, Page 868, passing a 3/4 inch iron pipe found at a distance of 333.18 feet, a total distance of **363.07 feet** to the **POINT OF BEGINNING**.



INNOVATIVE IDEAS  
EXCEPTIONAL DESIGN  
UNMATCHED CLIENT SERVICE

Containing **0.125 acre**, more or less, of which 0.010 acre is within highway right-of-way.

Iron rebar set, where indicated, are 30 inches in length, 5/8 inch in diameter with a plastic I.D. cap stamped "DLZ OHIO INC."

Property is subject to any and all previous easements and rights -of-way of record.

Bearings and distances, described herein, are derived from GPS observations based on Grid North, Ohio State Plane Coordinate System, North Zone, NAD83 (2011, Epoch 2010). Distances are expressed in U.S. Survey Feet. All other measurements are from angles and distances measured in a field survey by DLZ on September 21, 2020.

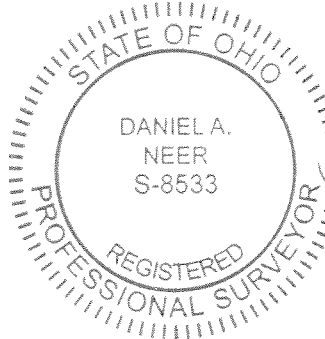

Description prepared by:

*D. A. Neer*  
Daniel A. Neer  
Professional Surveyor No. 8533  
October 14, 2020

2021-2104.00



✓ APPROVED



INNOVATIVE IDEAS  
EXCEPTIONAL DESIGN  
UNMATCHED CLIENT SERVICE

**DESCRIPTION OF A  
15 FOOT DRAINAGE EASEMENT  
SOUTH OF WHITE PINES DRIVE AND  
WEST OF TOWNSHIP ROAD 179**

Situated in Virginia Military survey 4478, City of Bellefontaine, Jefferson Township, Logan County, Ohio and being a 15 foot wide drainage easement over and across the 0.365 acre tract conveyed to the RPM Engineering LLC by deed of record in Official Record 1392, Page 3727, Tract II (all records herein are from the Recorder's Office, Logan County, Ohio) and being more particularly described as follows:

**Commencing** at a railroad spike found at the centerline intersection of Township Road 179 (60 feet in width) and White Pines Drive (60 feet in width);

Thence North  $84^{\circ}40'25''$  West, a distance of 143.89 feet, along the centerline of said White Pines Drive, to a point;

Thence South  $05^{\circ}19'35''$  West, a distance of 30.00 feet, over and across said White Pines Drive, to a point on the southerly right-of-way line and being a common corner to said 0.365 acre tract and a 2.203 acre tract conveyed to RPM Engineering LLC by deed of record in Official Record 1392, Page 3727, Tract I;

Thence South  $84^{\circ}40'25''$  East, a distance of 17.16 feet, along the line common to the southerly right-of-way line of said White Pines Drive and the northerly line of said 0.365 acre tract, to the **True Point of Beginning**;

Thence **South  $84^{\circ}40'25''$  East**, a distance of **15.02 feet**, continuing along the line common to the southerly right-of-way line of said White Pines Drive and the northerly line of said 0.365 acre tract, to a point;

Thence the following three (3) courses and distances over and across said 0.365 acre tract;

1. **South  $08^{\circ}25'38''$  West**, a distance of **17.23 feet**, to a point;
2. **South  $04^{\circ}48'56''$  East**, a distance of **87.31 feet**, to a point;
3. **South  $05^{\circ}42'54''$  West**, a distance of **37.15 feet**, to a point on the line common to said 0.365 acre tract and a 0.125 acre tract conveyed to RPM Engineering LLC by deed of record in Official Record 1392, Page 3771;

Thence **North  $83^{\circ}53'30''$  West**, a distance of **15.00 feet**, along the line common to the southerly line of said 0.365 acre tract and the northerly line of said 0.125 acre tract, to a point;

Thence the following three (3) courses and distances over and across said 0.365 acre tract;

1. **North  $05^{\circ}42'54''$  East**, a distance of **35.67 feet**, to a point;
2. **North  $04^{\circ}48'56''$  West**, a distance of **87.67 feet**, to a point;
3. **North  $08^{\circ}25'38''$  East**, a distance of **18.16 feet**, to the **Point of Beginning**. Containing **0.049 acre**, more or less.

INDEXED ON MAP

7355

6121 Huntley Rd, Columbus, OH 43229-1003 | OFFICE 614.888.0040 | ONLINE WWW.DLZ.COM

Akron Bellefontaine Bridgeville Burns Harbor Chicago Cincinnati Cleveland Columbus Detroit Flint Fort Wayne Indianapolis Joliet  
Kalamazoo Lansing Lexington Louisville Madison Melvindale Munster Muskegon Pittsburgh Port Huron Saint Joseph South Bend Toledo  
Waterford

Bearings and distances, described herein, are derived from GPS observations based on Grid North, Ohio State Plane Coordinate System, North Zone, NAD83 (2011, Epoch 2010). Distances are Expressed in U.S. Survey Feet. All other measurements are from angles and distances measured in a field survey by DLZ on September 21, 2020.



**DLZ Ohio Inc.**

Daniel A. Neer  
Professional Surveyor No. 8533

Date

C:\Users\dgrubb\AppData\Local\Microsoft\Windows\INetCache\Content.Outlook\HPMTABHD\Letterhead\_LegalSized.docx

INDEXED ON MAP  
7355

**DEED & SURVEY REFERENCES:**

REFERENCE DEEDS ARE SHOWN HEREON

LOGAN COUNTY ENGINEER'S MAP ROOM  
 FILES: 2645, 1360, 5469, 8585, 8281,  
 6864 AND 9336

(A) RPM ENGINEERING LLC  
 0.365 ACRE  
 O.R. 1392, PG. 3727  
 TRACT II

**BASIS FOR BEARINGS:**

BEARINGS AND DISTANCES, SHOWN HEREON,  
 ARE DERIVED FROM GPS OBSERVATIONS  
 BASED ON GRID NORTH, OHIO STATE PLANE  
 COORDINATE SYSTEM, NORTH ZONE, NAD83  
 (2011, EPOCH 2010).

**OCCUPATION NOTE:**

NO EVIDENCE OF OCCUPATION ALONG  
 BOUNDARY LINES, UNLESS OTHERWISE  
 SHOWN HEREON.

- ① P.O.B. TRACT A
- ② P.O.B. TRACT B

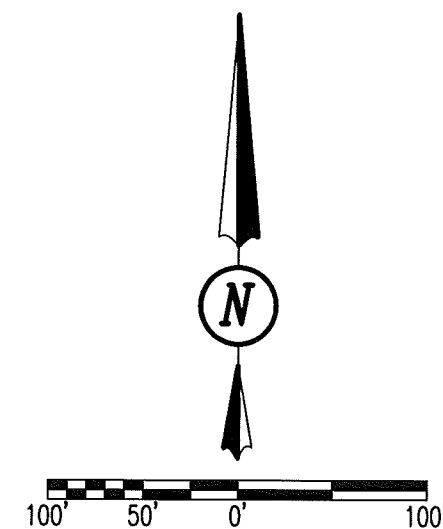

SCALE: 1" = 100'  
 DISTANCES SHOWN HEREON  
 ARE IN U.S. SURVEY FEET

LINE	BEARING	DISTANCE
L1	N 83°53'34" W	100.11'
L2	N 83°53'34" W	98.38'
L3	N 86°39'19" E	103.31'

ESMT. LINE TABLE		
LINE	BEARING	DISTANCE
E1	N 84°40'25" W	143.89'
E2	S 05°19'35" W	30.00'
E3	S 84°40'25" E	17.16'
E4	S 84°40'25" E	15.02'
E5	S 08°25'38" W	17.23'
E6	S 04°48'56" E	87.31'
E7	S 05°42'54" W	37.15'
E8	N 83°53'30" W	15.00'
E9	N 05°42'54" E	35.67'
E10	N 04°48'56" W	87.67'
E11	N 08°25'38" E	18.16'

WILLIAM A. SIEKIERKA  
 4.293 ACRES  
 O.R. 1322, PG. 114

LORI D. EDWARDS  
 3.207 ACRES  
 O.R. 177, PG. 820

RPM ENGINEERING LLC  
 0.125 ACRE  
 O.R. 1392, PG. 3771

DETAIL NTS

PREPARED BY:

*D. Neer*  
 DANIEL A. NEER  
 PROFESSIONAL SURVEYOR 8533  
 FIELD DATE: SEPTEMBER 21, 2020

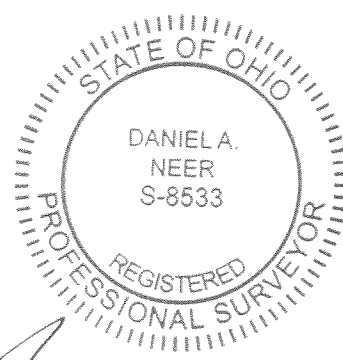

COPYRIGHT 2020 BY:  
**DLZ**  
 117 N. Madriver Street • Bellefontaine, OH 43311  
 (937) 593-7335 • www.dlz.com  
 Project #2021-2104.00

LEGEND		
⊙ 3/4 INCH IRON PIPE FOUND	C/L = CENTERLINE	
⊗ RAILROAD SPIKE FOUND	R/W = RIGHT-OF-WAY	
⊙ MAG NAIL SET	O.R. = OFFICIAL RECORD	
● 5/8 INCH BY 30 INCH IRON REBAR SET WITH PLASTIC I.D. CAP STAMPED "DLZ OHIO INC."	PG. = PAGE	
○ 5/8 INCH IRON REBAR FOUND	P.O.B. = POINT OF BEGINNING	
	P.O.C. = POINT OF COMMENCEMENT	
	NTS = NOT TO SCALE	

**BOUNDARY SURVEY**  
 VIRGINIA MILITARY SURVEY 4478  
 CITY OF BELLEFONTAINE  
 JEFFERSON TOWNSHIP  
 LOGAN COUNTY, OHIO

DRAWN BY:	DESCRIPTION	REV. NO.	DATE
DAN			9/1/2020
DCC			9/22/2020
DAN	REVISED TO ADD PROP. DRAINAGE EASEMENT		11/3/2020
DAN	REVISED TO UPDATE ADJOINERS		11/5/2020
DAN	REVISED TO REMOVE EASEMENT		11/6/2020

INDEXED ON MAP  
 7355

# Pine Knoll Subdivision

Virginia Military Survey 4478

City of Bellefontaine

Township of Jefferson, County of Logan, State of Ohio

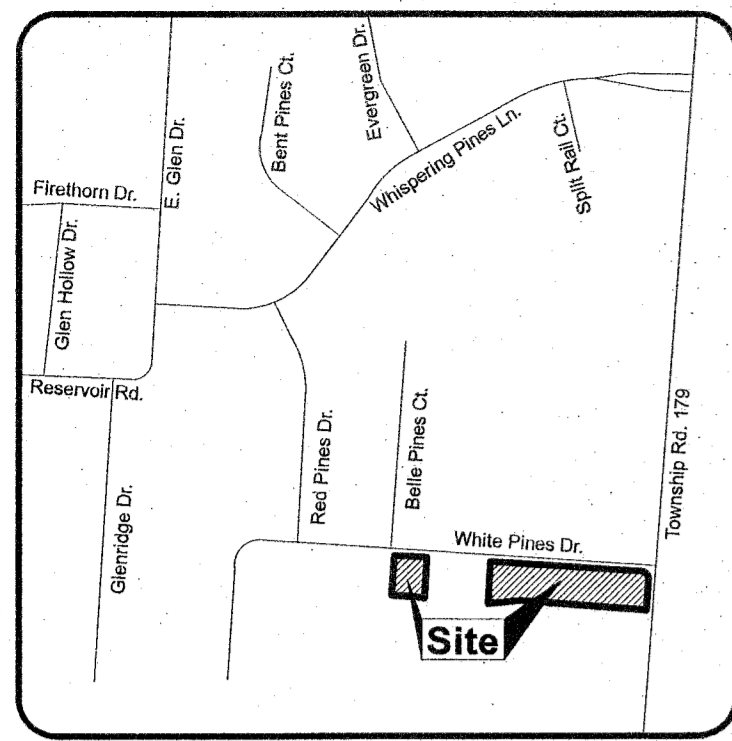

VICINITY MAP  
Not to Scale

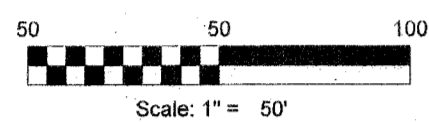

LEGEND

- 5/8 - inch Iron Rebar Found
- 5/8 - inch Iron Rebar Set, 30 inches in length, with a yellow cap stamped: "DLZ OHIO INC."
- Magnetic Nail Set
- ⊗ Railroad Spike Found
- ⊙ 3/4 - Inch Iron Pipe Found
- R/W = Right of Way
- C/L = Center-line
- N.T.S. = Not to Scale
- B/L = Building Line
- 5143 Lot Numbers
- 1700 Street Address

### DEED RESTRICTIONS:

1. Each lot shall be used for single family residential purposes only.
2. Each lot shall contain only one dwelling house and every dwelling house shall have an attached two car garage.
3. Construction on a dwelling house shall not begin until its design is approved in writing by RPM Engineering LLC or their successor(s) if needed.
4. No other improvements such as outbuildings, sheds, pole barns, gazebos, and the like shall be permitted unless first approved in writing by the Grantor(s).
5. No dwelling house or other building shall be erected, altered, placed, or permitted to remain on the above described premises that exceeds two and one-half (2 1/2) stories in height and in no event shall any dwelling house or other building be erected to a height exceeding thirty five (35) feet from the finish grade of the dwelling house or building.
6. Any above or below ground swimming pools must be fenced in per city regulation codes.
7. No business, trade or other commercial activity shall be conducted upon any lot.
8. At no time shall a chain-link or non-painted/non-stained wooden fence be permitted on any lot.
9. No lot shall be used or maintained as a dumping ground for rubbish, trash, garbage, vehicles or like objects.
10. No clothesline shall be permitted anywhere on a lot.
11. No motor vehicle shall be left upon or abutting a lot for a period longer than thirty (30) days, within a ninety (90) day period, in a condition wherein the motor vehicle is not able to be operated upon the public street or highway. After such period the motor vehicle shall be considered a nuisance and shall be removed at the motor vehicle owner's expense.
12. All dwelling houses shall have a minimum roof pitch of 8-12 rise over run.
13. All dwelling houses shall have a minimum porch roof pitch of 4-12 rise over run.
14. All dwelling houses shall contain the following prescribed minimum square footage of living area, exclusive of basement, porches, breezeway, and garage areas:
  - Ranch Style home 1500 sq. ft. first floor
  - Multi-level or split-level 1700 sq. ft. with 1100 sq. ft. above grade
  - One and a half story home 1700 sq. ft., no less than 1100 sq. ft. on first floor
  - Two-story home 1800 sq. ft., no less than 1100 sq. ft. on first floor
15. All dwelling houses or other buildings shall have exterior coverings of wood, shingle, brick, stone, stucco or vinyl. No used lumber or other building materials shall be used as the exterior coverings on any dwelling house or other building except reclaimed brick or other new or modern materials may be utilized when architecturally compatible with the design of the dwelling house or other building.
16. Exterior metal siding with respect to any dwelling house or other building shall be prohibited.
17. The front of each dwelling house shall have a minimum of thirty percent (30%) exterior finish of brick, stone, and/or pre-cast cultured stone. A dwelling house with a covered front porch across the entire front of the home shall be excluded from this brick, stone, and/or pre-cast/cultured stone requirement.
18. No billboard sign, or advertising device of any kind other than a "For Sale" sign shall be permitted. This restriction does not include the display of any traditional American flag.
19. All trash, rubbish and/or recycling containers shall be maintained either inside the garage or housed to the rear of the residence and shall be returned to their place of origin within twelve (12) hours of any scheduled trash or recycle pick up.
20. All dwelling houses shall have concrete driveways. Asphalt driveways shall not be permitted on a lot.

**Point of Beginning**  
(0.295 acre)

**Begin for Reference**  
(1.468 acres)

CURVE	DELTA ANGLE	RADIUS	ARC LENGTH	CHORD BEARING	CHORD LENGTH
C1	90°00'04"	25.00'	39.27'	S 39°40'23" E	35.36'

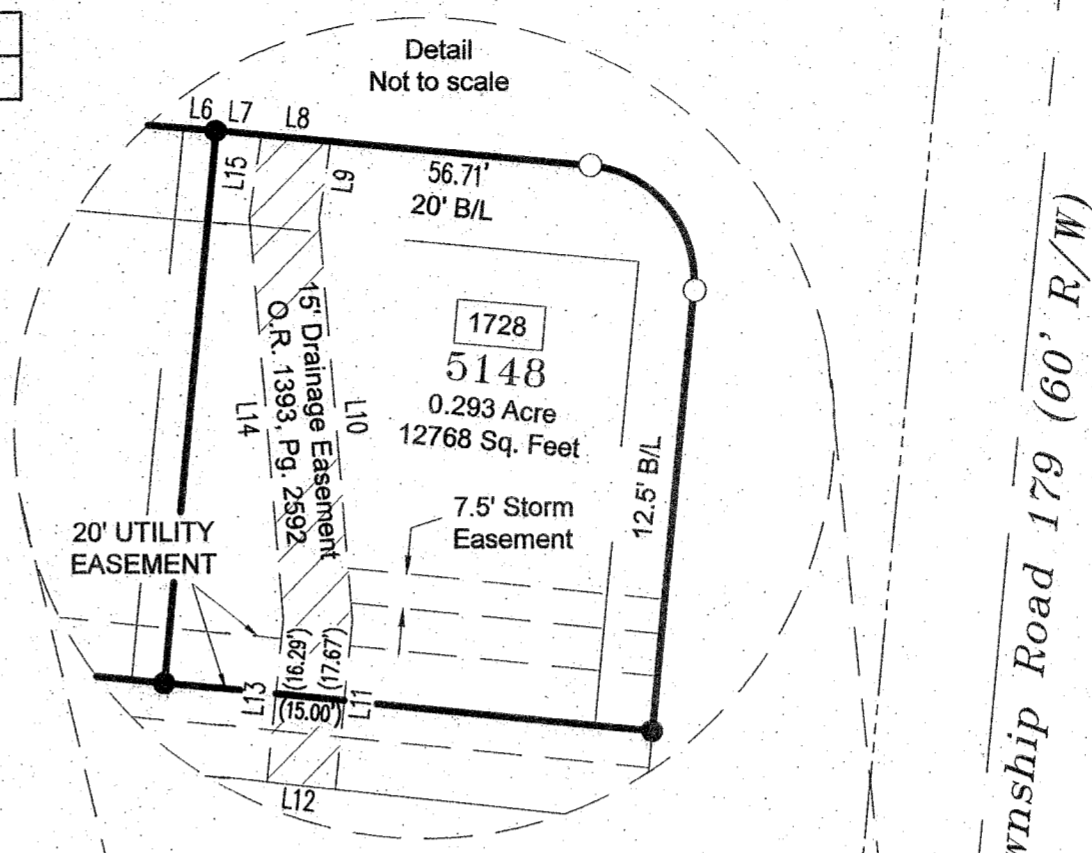

LINE	BEARING	DISTANCE
L6	S 84°40'25" E	17.20'
L7	S 84°40'25" E	9.96'
L8	S 84°40'25" E	15.02'
L9	S 08°25'38" W	17.23'
L10	S 04°48'56" E	87.31'
L11	S 05°42'54" W	37.15'
L12	N 83°53'34" W	15.00'
L13	N 05°42'54" E	35.67'
L14	N 04°48'56" E	87.67'
L15	N 08°25'38" E	18.16'

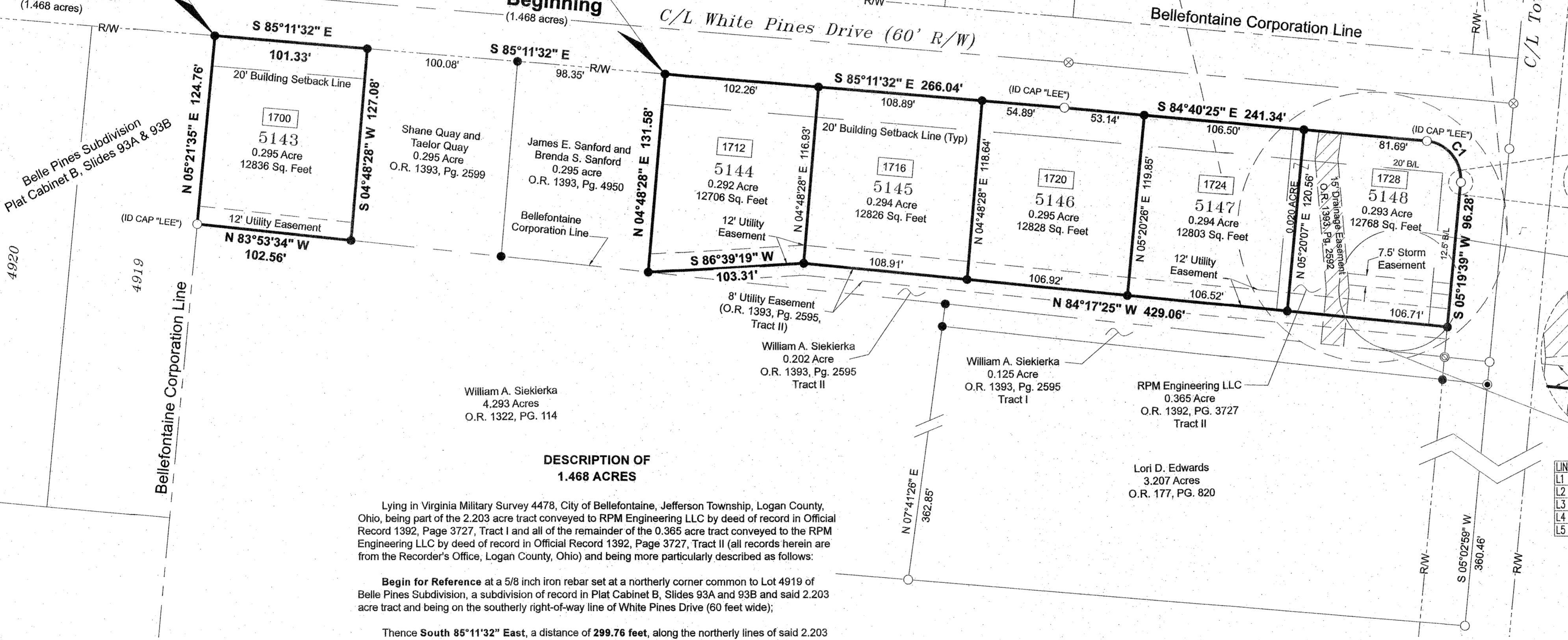

### DESCRIPTION OF 1.468 ACRES

Lying in Virginia Military Survey 4478, City of Bellefontaine, Jefferson Township, Logan County, Ohio, being part of the 2.203 acre tract conveyed to RPM Engineering LLC by deed of record in Official Record 1392, Page 3727, Tract I and all of the remainder of the 0.365 acre tract conveyed to the RPM Engineering LLC by deed of record in Official Record 1392, Page 3727, Tract II (all records herein are from the Recorder's Office, Logan County, Ohio) and being more particularly described as follows:

**Begin for Reference** at a 5/8 inch iron rebar set at a northerly corner common to Lot 4919 of Belle Pines Subdivision, a subdivision of record in Plat Cabinet B, Slides 93A & 93B and said 2.203 acre tract and being on the southerly right-of-way line of White Pines Drive (60 feet wide);

Thence **South 85°11'32" East**, a distance of **299.76 feet**, along the northerly lines of said 2.203 acre tract, a 0.295 acre tract conveyed to Shane Quay and Taelor Quay, by deed of record in Official Record 1393, Page 2599, a 0.295 acre tract conveyed to James E. Sanford and Brenda S. Sanford, by deed of record in Official Record 1393, Page 4950 and the southerly right-of-way line of said White Pines Drive, to a 5/8 inch rebar set at the northeasterly corner of said Sanford 0.295 acre tract and being the **True Point of Beginning**;

Thence **South 85°11'32" East**, a distance of **266.04 feet**, along the line common to the northerly line of said 2.203 acre tract and the southerly right-of-way line of said White Pines Drive, to a 5/8 inch rebar found (I.D. cap "LEE");

Thence **South 84°40'25" East**, a distance of **241.33 feet**, along the line common to the northerly lines of said 2.203 acre tract, said 0.365 acre tract and the southerly right-of-way line of said White Pines Drive, to a 5/8 inch rebar found (I.D. cap "LEE") at a point of curvature;

Thence along the common boundary to the northerly boundary of said 0.365 acre tract and the southerly right-of-way line of said White Pines Drive and along a curve to the right having a delta angle of **90°00'04"**, a radius of **25.00 feet**, an arc length of **39.27 feet**, a chord bearing **South 39°40'23" East** and a chord length of **35.36 feet**, to a point of tangency and being referenced by a 5/8 inch rebar found (I.D. cap "LEE"), bearing **South 88°13'37" East**, a distance of **0.09 feet**;

Thence **South 05°19'39" West**, a distance of **96.28 feet**, along the line common to the easterly line of said 0.365 acre tract and the westerly right-of-way line of Township Road 179 (60 feet wide), to a 5/8 inch rebar set at the northeasterly corner of the 0.202 acre tract conveyed to William A. Siekierka by deed of record in Official Record 1393, Page 2595, Tract II;

Thence the following two (2) courses and distances along the northerly line of said 0.202 tract:

**1. North 84°17'25" West**, a distance of **429.06 feet**, to a 5/8 inch rebar set;

**2. South 86°39'19" West**, a distance of **103.31 feet**, to a 5/8 inch rebar set at the southeasterly corner of said Sanford 0.295 acre tract and being on the northerly line of a 4.293 acre tract conveyed to William A. Siekierka by deed of record in Official Record 1322, Page 114;

Thence **North 04°48'28" East**, a distance of **131.58 feet**, along the easterly line of said Sanford 0.295 acre tract, to the **Point of Beginning**.

Containing 1.468 acres, more or less, of which 1.155 acres are out of said 2.203 acre tract and 0.313 acre is all of the remainder of said 0.365 acre tract, and being subject to easements, restrictions and right-of-way of record.

### DESCRIPTION OF 0.295 ACRE

Lying in Virginia Military Survey 4478, City of Bellefontaine, Jefferson Township, Logan County, Ohio, and being part of the 2.203 acre tract conveyed to RPM Engineering LLC by deed of record in Official Record 1392, Page 3727, Tract I (all records herein are from the Recorder's Office, Logan County, Ohio) and being more particularly described as follows:

**Beginning** at a 5/8 inch rebar set at a northerly corner common to Lot 4919 of Belle Pines Subdivision a subdivision of record in Plat Cabinet B, Slides 93A & 93B and said 2.203 acre tract and being on the southerly right-of-way line of White Pines Drive (60 feet wide);

Thence **South 85°11'32" East**, a distance of **101.33 feet**, along a common line to the northerly line of said 2.203 acre tract and the southerly right-of-way line of said White Pines Drive, to a 5/8 inch rebar set at the northwest corner of a 0.295 acre tract, as conveyed to Shane Quay and Taelor Quay by deed of record in Official Record 1393, Page 2599;

Thence **South 04°48'28" West**, a distance of **127.08 feet**, along the westerly line of said 0.295 acre tract, to a 5/8 inch rebar set on a common line to the northerly line of the 4.293 acre tract conveyed to William A. Siekierka by deed of record in Official Record 1322, Page 114 and the southerly line of said 2.203 acre tract and the Bellefontaine Corporation line;

Thence **North 83°53'34" West**, a distance of **102.56 feet**, along said common line, to a 5/8 inch rebar found (I.D. cap "LEE") on the easterly line of said Lot 4919;

Thence **North 05°21'35" East**, a distance of **124.76 feet**, along the line common to the westerly line of said 2.203 acre tract and the easterly line of said Lot 4919, to the **Point of Beginning**.

Containing 0.295 acre, more or less, and being subject to easements, restrictions and right-of-way of record.

### NOTES:

1. This plat consists of one (1) page.
2. In addition to other easements shown or noted, an exclusive two feet diameter easement is reserved at all property corners and points of curvature for monumentation. No surface or buried utilities of any kind may be placed within these easement areas.
3. The utility easements indicated on this plat are for the erection, construction, maintenance, repair, and installation of any or all utilities for use within the Pine Knoll Subdivision. It shall be lawful for any such utility or its employees or representatives or anyone acting for any such utility to enter upon said easement or right-of-way at any time for the purpose of carrying out the objectives for which such easements or rights-of-way were reserved. No structures or plantings are permitted within any utility easement.
4. Building setback distances shall conform to the Bellefontaine City Zoning Regulations for an R-1 Zone. The 20' front setback variance was granted by the City of Bellefontaine Board of Zoning Appeals in Case #2020-10 on August 8, 2020.

### Owner / Developer:

RPM Engineering LLC  
Managing Member - Rich Moldas  
101 Bell Pines Court  
Bellefontaine, Ohio 43311

### DEDICATION

Known all men by these presents that Rich Moldas, as managing member of RPM Engineering LLC, owner of the lands indicated on the accompanying plat, has authorized the platting thereof.

In witness thereof, the following have set their hand this 23 day of December, 2020.

MANAGING MEMBER

By: *Rich Moldas*  
Rich Moldas

Signed and acknowledged in the presence of:

Signature: \_\_\_\_\_ Witness

Printed Name: \_\_\_\_\_

Signature: \_\_\_\_\_ Witness

Printed Name: \_\_\_\_\_

State of Ohio  
County of Logan

Before me, a Notary Public in and for said County, personally appeared Rich Moldas, who acknowledged the signing of the foregoing instrument to be his voluntary act and deed for the uses and purposes therein expressed.

In witness whereof, I have hereunto set my hand and affixed my official seal this 23 day of December, 2020

Signature: *Linn H. Baker*  
Notary Public

My commission expires: 8/24/21



### APPROVALS

Approved this 17th day of December, 2020: *Ben Stahlor*  
Mayor

Approved this 18th day of December, 2020: *John L. Dine*  
Chairman, Bellefontaine City Planning Commission

Approved this \_\_\_ day of \_\_\_, 2020: *Bonnie Campbell*  
Clerk, Bellefontaine City Council

Preapproval: *Joseph M. Cochran* 12-17-2020

Plat checked: *Joseph M. Cochran* 12-23-2020

Transferred this 23 day of Dec., 2020, *Patricia W. Myer*  
Auditor, Logan County, Ohio

Recorded in Plat Cabinet B, Slide 147B Received for Record at 3:19 P.M.  
This 20th day of December, 2020

Signature: *Patricia W. Myer*  
Recorder, Logan County, Ohio

### SURVEYORS CERTIFICATION:

The accompanying plat represents a subdivision of land in Virginia Military Survey 4478, City of Bellefontaine, Township of Jefferson, County of Logan, State of Ohio.  
The Lots have a total area of 1.763 acres.  
All measurements are in U.S. Survey feet and decimal parts thereof.

I hereby state that the accompanying plat is a correct representation of Pine Knoll Subdivision as surveyed in September, 2020, and that all monuments are as shown hereon have been found, set, or will be set upon completion of construction at a time as directed by the proprietors.

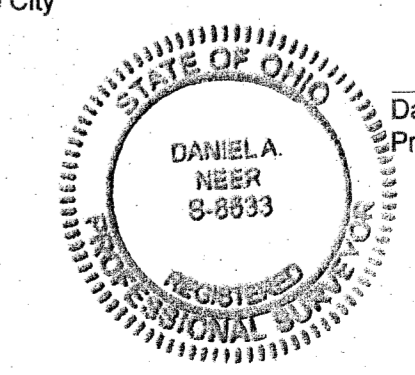

Signature: *Daniela A. Neer*  
Professional Surveyor No. 8533  
Date: 12-16-20

Scale: 1" = 50'  
Date: October, 2020  
DLZ Job No.: 2021-2104.00



117 N. Madriver Street • Bellefontaine, OH 43311  
(937) 593-7335 • www.dlz.com

A-223