



# Lee Surveying and Mapping Co.



Farm Surveys • Lot Surveys • Topography • Subdivisions • Construction Layout

143 EAST COLUMBUS AVENUE  
BELLEFONTAINE, OHIO 43311

(513) 593-7335

JEFFREY I. LEE, P.S.

## ARNDTS (0.104 ACRE)

Lying in Section 30, Town 3, Range 14, Harrison Township, Logan County, Ohio.

Being out of the David C. Arndts 2.573 acre tract as deeded and described in Official Record 102, Page 262 of the Logan County Records of Deeds and being more particularly described as follows:

Beginning at a railroad spike found on the north line of Section 30 and the center-line of Township Road 212 at the northwest corner of the aforesaid 2.573 acre tract. Said railroad spike is S 85°-02'-00" E along the section line, a distance of 285.00 feet from a railroad spike found at the northwest corner of the northeast quarter of Section 30.

THENCE, with the north line of Section 30 and the center-line of Township Road 212, S 85°02'00" E, a distance of 15.00 feet to a railroad spike set.

THENCE, S 4°58'00" W, a distance of 308.35 feet to a 5/8 inch iron rod set on the easterly line of the Albert Arndts 2.972 acre tract (O.R. 146, Pg. 410).

THENCE, with the easterly line of the said 2.972 acre tract, N 40°25'00" W, a distance of 21.07 feet to a 5/8 inch iron rod found.

THENCE, with the east line of the Albert Arndts, Jr. 1.001 acre tract (O.R. 42, Pg. 598), N 4°58'00" E, a distance of 293.55 feet to the point of beginning.

Containing 0.104 acre of which 0.007 acre is within the highway right-of-way.

The basis for bearings is based upon the north line of Section 30 being S 85°-02'-00" E, and all other bearings are from angles and distances measured in a field survey by Lee Surveying and Mapping Company on April 9, 1993.

Description prepared by:

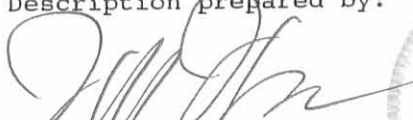
  
Jeffrey I. Lee  
Professional Surveyor 6359  
April 10, 1993

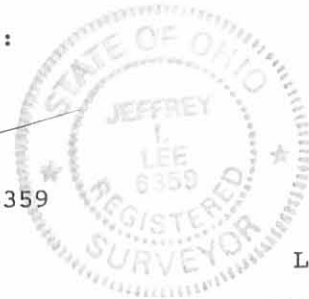

L 1030

ORIGINAL STAMP IN GREEN

INDEXED ON MAP  
6899 ID

FRACTIONAL SECTION 25  
 TOWNSHIP ROAD 212 (40')  
 SECTION 30

QUARTER-SECTION LINE

ALBERT ARNDTS, JR.  
 1.001 AC.  
 O.R. 42. PG. 598

ALBERT L. ARNDTS  
 2.972 AC.  
 O.R. 146. PG. 410

DAVID C. ARNDTS  
 2.573 AC. (DEED)  
 O.R. 102. PG. 262

0.104 ACRE  
 OF WHICH 0.007 ACRE IS  
 WITHIN THE ROAD  
 RIGHT-OF-WAY

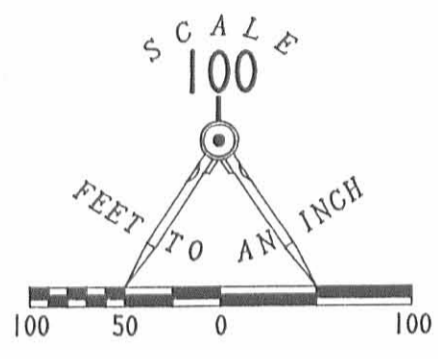

LEGEND

- ⊗ RAILROAD SPIKE FOUND
- ⊙ COTTON GIN SPINDLE FOUND
- 5/8" IRON ROD FOUND
- PK NAIL FOUND
- ⊕ RAILROAD SPIKE SET
- 5/8" IRON ROD SET

REFERENCE:  
 LOGAN COUNTY ENGINEER'S FIELD BOOK 588. PP. 63 -64

SURVEY OF 0.104 ACRE  
 OUT OF THE DAVID C. ARNDTS  
 2.573 ACRES (OFFICIAL RECORD 102, PAGE 262  
 SECTION 30, TOWN 3, RANGE 14  
 HARRISON TOWNSHIP  
 LOGAN COUNTY, OHIO

SURVEYED BY:



*Jeffrey L. Lee*  
 JEFFREY L. LEE  
 PROFESSIONAL SURVEYOR 6359  
 APRIL 9, 1993

INDEXED ON MAP  
 68991P

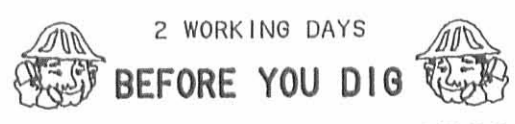

CALL TOLL FREE 800-362-2764  
 OHIO UTILITIES PROTECTION SERVICE.

ORIGINAL STAMP IN GREEN  
**LEE SURVEYING & MAPPING CO.**  
 143 East Columbus Avenue  
 BELLEFONTAINE, OHIO 43311  
 (513) 593-7335

# Lee Surveying and Mapping Co.



Farm Surveys • Lot Surveys • Topography • Subdivisions • Construction Layout

855 EAST SANDUSKY AVENUE  
BELLEFONTAINE, OHIO 43311

(513) 593-5780

CLAYTON M. LEE, P.S.  
JEFFREY I. LEE, P.S.

## ROPP SURVEY

Lying in The NW  $\frac{1}{4}$  of the NE  $\frac{1}{4}$  of Section 30, T-3, R-14, Harrison Township, Logan County, Ohio.

Being the very northwest corner of that property lying in the name of Donald Ropp as deeded and described in Volume 400, Page 557 (Tract 2) of the Logan County Records of Deeds, being more particularly described as follows:

Beginning at a railroad spike set on the center-line of County Road 212, marking the northwest corner of said Ropp property and being 59.48 feet east along said center-line from the center-line of abandoned C.C.C. & St. L. Railroad.

THENCE, with the center-line of County Road 212 (North line of Section 30), S  $85^{\circ}-02'$  E, a distance of 285.00 feet to a railroad spike.

THENCE, at right angles, S  $4^{\circ}-58'$  W, a distance of 293.55 feet to an iron rod set on the northeast right-of-way line of said railroad.

THENCE, with the said northeast right-of-way line, N  $40^{\circ}-25'$  W, a distance of 400.47 feet to the west line of the said northeast quarter of Section 30.

THENCE, with said west line of said quarter-section, N  $4^{\circ}-40'$  E, a distance of 12.40 feet to the point of beginning. Containing 1.001 acre.

Last previous deed reference: Volume 400, Page 557 (Tract 2).

Prepared by:

*Clayton M. Lee*

Clayton M. Lee  
Reg. Surveyor No. 6181  
11-10-83

6899 2D-1



INDEXED ON MAP

ORIGINAL STAMP IN GREEN

L-1030

# Lee Surveying and Mapping Co.



CLAYTON M. LEE, P.S.  
JEFFREY I. LEE, P.S.

855 East Sandusky Avenue  
Bellefontaine, Ohio 43311  
Phone 593-5780



Farm Surveys • Lot Surveys • Topography • Subdivisions • Construction Layout

ROPP ( 2.573 ACRES )

Lying in the northwest quarter of the northeast quarter of Section 30, T-3, R-14, Harrison Township, Logan County, Ohio.

Being out of the Ropp property (Volume 400, Page 557, Tract 2) and being particularly out of the part of said Tract 2 that lies north of the C.C.C. & St. L. Railroad.

Beginning at a railroad spike set on the center-line of County Highway 212 marking the northeast corner of said Tract 2 and shown on Logan County Engineer's survey records as being Station 53+51 (F.B. 588, Page 64). Also being the north line of Section 30.

THENCE, with the said center-line of County Highway 212 and section line, N 85°-02" W, a distance of 785.70 feet to a railroad spike. THE TRUE POINT OF BEGINNING.

THENCE, parallel to the east line of said grantor's Tract 2, S 4°-49'-04" W, a distance of 554.78 feet to a 5/8" iron rod set on the north right-of-way line of the C.C.C. & St. L. Railroad.

THENCE, with said north right-of-way line, N 40°-29' W, a distance of 219.17 feet to a 5/8" iron rod set at a 0°-04' angle to the right.

THENCE, continuing with said north right-of-way line, N 4°-25' W, a distance of 153.03 feet to a 5/8" iron rod.

THENCE, N 4°-58' E, a distance of 293.55 feet to a railroad spike set on the center-line of County Highway 212, passing an iron rod at 268.55 feet.

THENCE, with said center-line of County Highway 212, S 85°-02' E, a distance of 263.68 feet to the point of beginning.

Containing 2.573 acres.

Prepared by:

  
Clayton M. Lee  
Registered Surveyor No. 6181  
12-25-84

6899 2D-2

INDEXED ON MAP

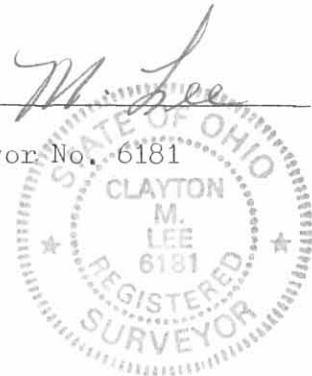

ORIGINAL STAMP IN GREEN  
L-1030

# Lee Surveying and Mapping Co.



CLAYTON M. LEE, P.S.  
JEFFREY I. LEL, P.S.

855 East Sandusky Avenue  
Bellefontaine, Ohio 43311  
Phone 593-5780



Farm Surveys • Lot Surveys • Topography • Subdivisions • Construction Layout

## ROPP (17 ACRES)

Lying in the northwest quarter of the northeast quarter of Section 30,  
T-3, R-14, Harrison Township, Logan County, Ohio.

Being out of the Ropp property (Volume 400, Page 557, Tract 2) and  
being particularly out of the part of said Tract 2 that lies north of the  
C.C.C. & St. L. Railroad.

Beginning at a railroad spike set on the center-line of County High-  
way 212 marking the northeast corner of said Tract 2 and shown on Logan  
County Engineer's survey records as being Station 53+51 (F.B. 588, Page 64).  
Also being the north line of Section 30.

THENCE, with the east line of said Tract 2, S 4°-49'-04" W, a dis-  
tance of 1330.22 feet to a 5/8" iron rod set on the north right-of-way  
line of said railroad, passing a 5/8" iron rod set at 25.0 feet.

THENCE, with said north right-of-way line, N 40°-29' W, a distance  
of 1105.35 feet to a 5/8" iron rod.

THENCE, parallel to the east line, N 4°-49'-04" E, a distance of  
554.78 feet to a railroad spike set on the center-line of County Highway  
212, passing a 5/8" iron rod at 529.78 feet.

THENCE, with said center-line of County Highway 212, S 85°-02' E,  
a distance of 785.70 feet to the point of beginning.

Containing 17.00 acres.

Prepared by:

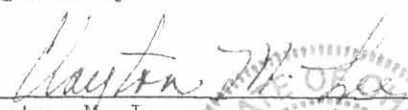
  
Clayton M. Lee  
Registered Surveyor No. 6181  
12-24-84

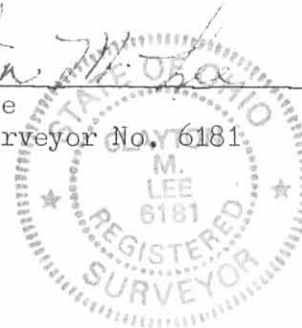

ORIGINAL STAMP IN GREEN

6899 2D-3

INDEXED ON MAP





# Lee Surveying and Mapping Co.



Farm Surveys • Lot Surveys • Topography • Subdivisions • Construction Layout

143 EAST COLUMBUS AVENUE  
BELLEFONTAINE, OHIO 43311

(513) 593-7335

JEFFREY I. LEE, P.S.

## PENN CENTRAL CORPORATION (2.972 ACRES)

Lying in Section 30, Town 3, Range 14, Harrison Township, Logan County, Ohio.

Being all of a 66.0 feet wide tract of land lying in the name of the Penn Central Corporation extending from the north line of Section 30 and the center-line of Township Road 212 southeasterly to the north-south 1/16 section line of the northeast quarter of said Section 30 and being more particularly described as follows:

Beginning at a cotton gin spindle set on the north line of Section 30, N 85°-02'-00" W, a distance of 12.50 feet from a railroad spike found at the northwest corner of the northeast quarter of said Section 30.

THENCE, with the southwesterly lines of the Albert Arndts, Jr 1.001 acre tract (O.R. 42, Pg. 598) and the David C. Arndts 2.573 acre tract (O.R. 102, Pg. 262), S 40°-25'-00" E, a distance of 571.15 feet to a 5/8 inch iron rod found.

THENCE, continuing with the southwesterly line of the said 2.573 acre tract and with the southwesterly line of the Randel Hurst 17.00 acre tract (O.R. 2, Pg. 340), S 40°-29'-00" E, a distance of 1324.52 feet to a 5/8 inch iron rod found at the southwest corner of the Michael Bow 11.235 acre tract (Vol. 392, Pg. 296).

THENCE, through the Penn Central Corporation property S 4°-49'-04" W, a distance of 92.85 feet to a 5/8 inch iron rod found.

THENCE, with the northeasterly line of the Donald Ropp original 77.18 acre tract (Vol. 400, Pg. 557), N 40°-29'-00" W, a distance of 1390.25 feet to a 5/8 inch iron rod found.

THENCE, continuing with the northeasterly line of the said 77.18 acre tract and the northeasterly line of the Robert Moody 13.5 acre tract (Vol. 344, Pg. 165), N 40°-25'-00" W, a distance of 637.69 feet to a cotton gin spindle set on the north line of Section 30.

THENCE, with the north line of Section 30 and the center-line of Township Road 212, S 85°-02'-00" E, a distance of 93.97 feet to the point of beginning.

Containing 2.972 acres of which 0.043 acre is within the highway right-of-way.

The basis for bearings is based upon the north line of Section 30 being S 85°-02'-00" E, and all other bearings are from angles and distances measured in actual field surveys by Lee Surveying and Mapping Company in December of 1984 and on December 4, 1991.

Description prepared by:

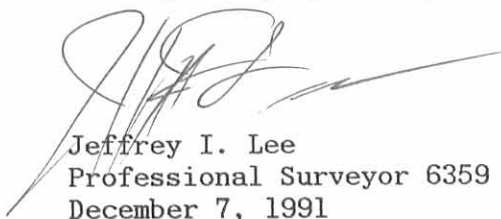
  
Jeffrey I. Lee  
Professional Surveyor 6359  
December 7, 1991

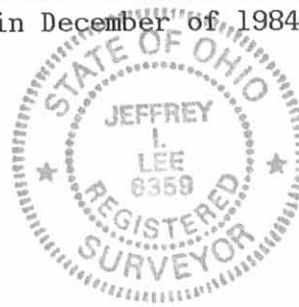

ORIGINAL STAMP IN GREEN

INDEXED ON MAP  
68993D

THE PENN CENTRAL CORPORATION  
 CASE NO. FR88305  
 SECTION 30, TOWN 3, RANGE 14  
 HARRISON TOWNSHIP, LOGAN COUNTY, OHIO

REFERENCES

- LOGAN COUNTY ENGINEER'S RECORDS:  
 ROAD RECORD BOOK 3, PAGE 240  
 FILE R-847  
 FILE R-5093  
 FIELD BOOK 588, PP. 63 - 64  
 FIELD BOOK 516, PP. 11 - 13  
 NEW YORK CENTRAL RIGHT-OF-WAY MAP V-303/15  
 WARRENTY DEED VOLUME 95, PAGE 399  
 QUIT CLAIM DEED VOLUME 141, PAGE 620

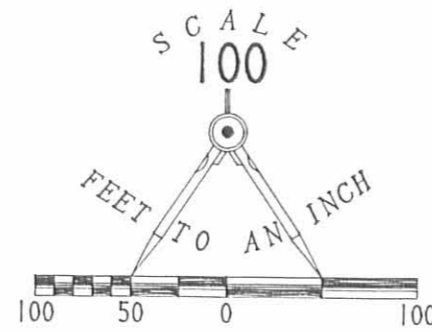

LEGEND

- ⊗ RAILROAD SPIKE FOUND
- 5/8" I. ROD FOUND
- ⊠ RAILROAD RAIL ON END FOUND
- ⊙ COTTON GIN SPINDLE SET
- 5/8" I. ROD SET

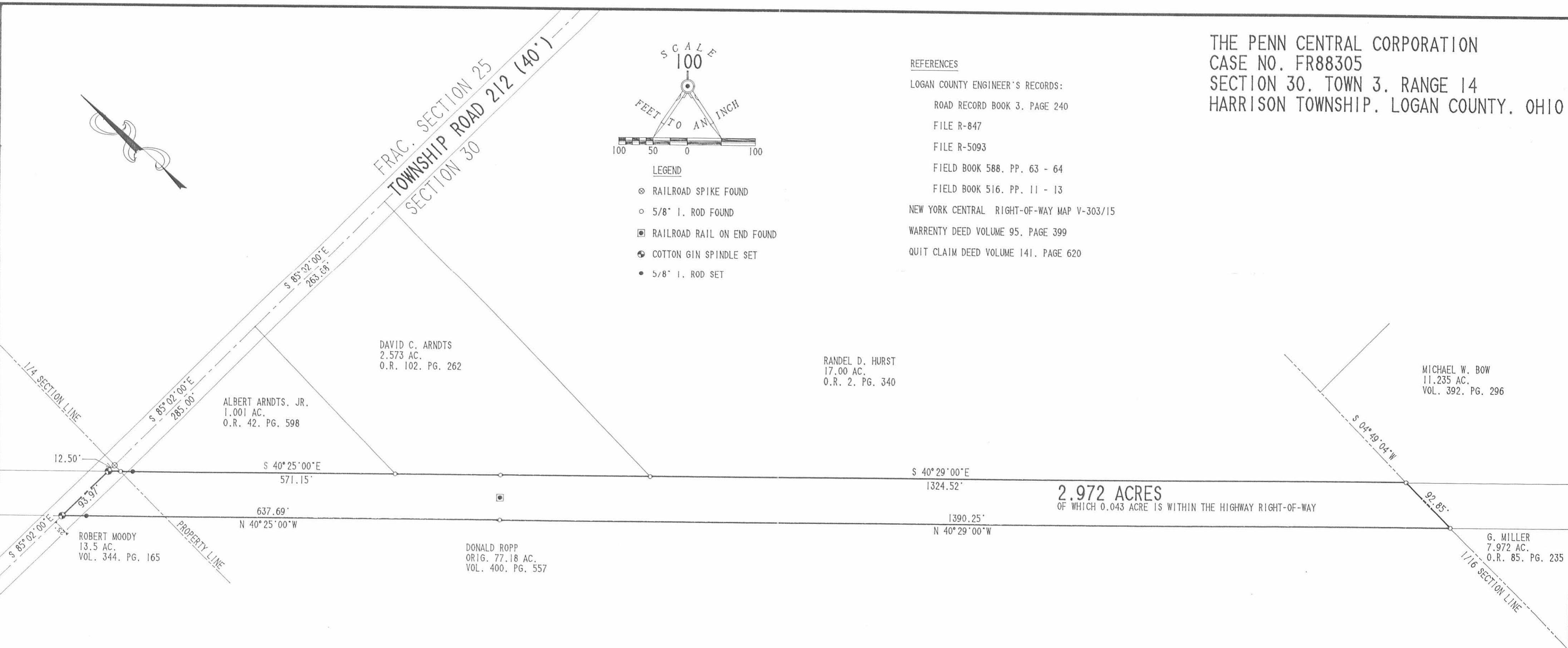

**SURVEY OF 2.972 ACRES OUT OF  
 THE PENN CENTRAL CORPORATION LANDS  
 SECTION 30, TOWN 3, RANGE 14  
 HARRISON TOWNSHIP  
 LOGAN COUNTY, OHIO**



SURVEYED BY:  
*Jeffrey I. Lee*  
 JEFFREY I. LEE  
 PROFESSIONAL SURVEYOR 6359  
 DECEMBER 4, 1991  
 LEE SURVEYING & MAPPING CO.  
 143 East Columbus Avenue  
 BELLEFONTAINE, OHIO 43311  
 (513) 593-7335

ORIGINAL STAMP IN GREEN

DISK 59 L1030RR L 1030-2

INDEXED ON MAP  
 6899 3D

INDEXED ON MAP  
 6899